

FACTORY FURNITURE

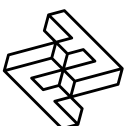

Bloc Wood Double Bin

TECHNICAL SHEET



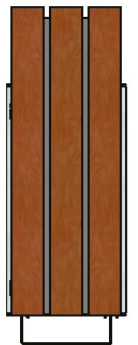
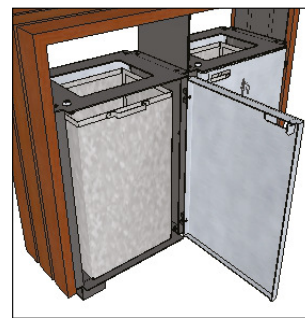
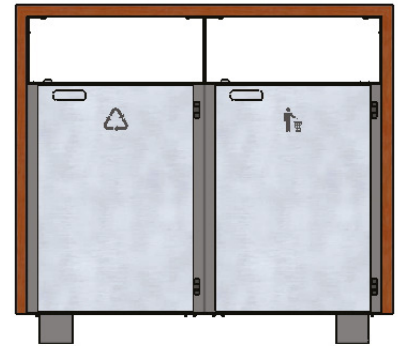
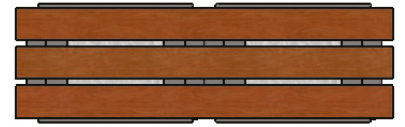
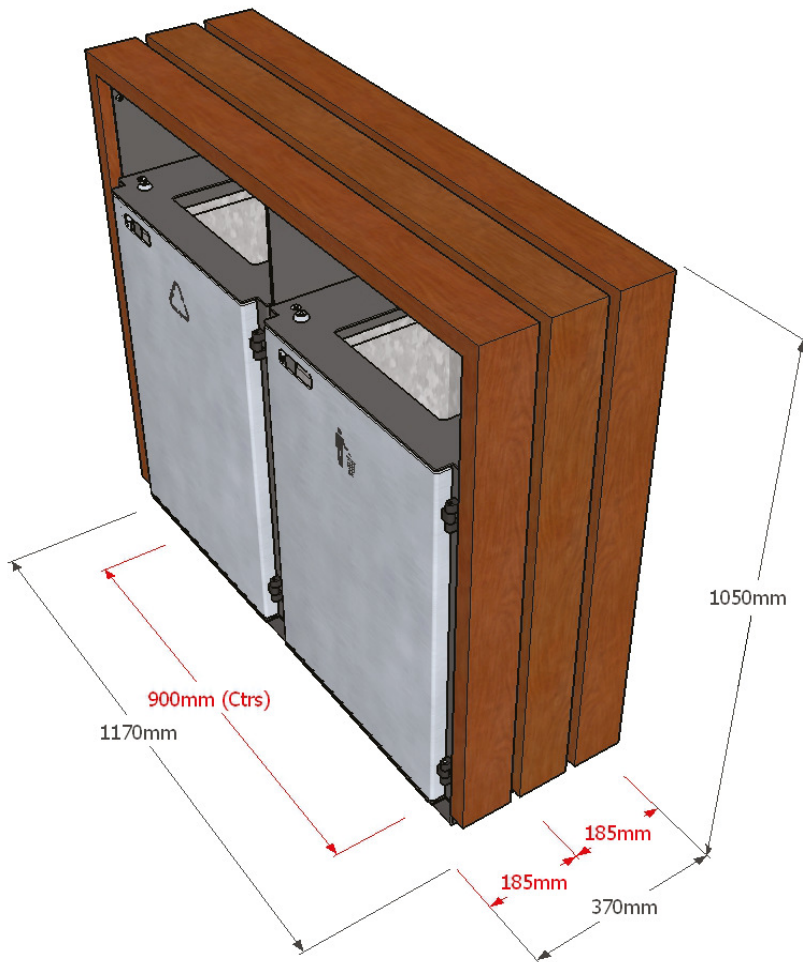

Composition

Slats - FSC® certified hardwood



Frame - Galvanised & powder-coated mild steel* (*stainless steel option available*)

Front & rear panels - Satin polished stainless steel

Bin liner - Pre-galvanised mild steel sheet

Doors at front with slam lock to access removable bin liners

Dimensions

Metric L 1170mm | width 370mm | height 1050mm

Imperial L 3' 10" | width 1' 2½" | height 3' 5½"

Bin liner capacity

75ltrs (2 liners per bin)

Approx weight

152kg

Fixing centres

900mm (2' 11½")

Fixing method

2 no. resin fixed anchors (concealed in base)

Foundation

1 no. pad 1200 x 400 x 400 mm in C20 concrete (recommendation only)

Handling

Please observe health and safety lifting guidelines. A forklift or crane will be required for off-loading and positioning of product.

Maintenance

Depends on usage and position. All elements require annual cleaning. Galvanised and powder coated mild steel only require maintenance if damaged. Stainless steel requires no further maintenance.

**Please note that when a powdercoat is applied over a hot dip galvanised surface pinholing can occur in the surface finish - this is not considered a defect.*

