

FACTORY FURNITURE

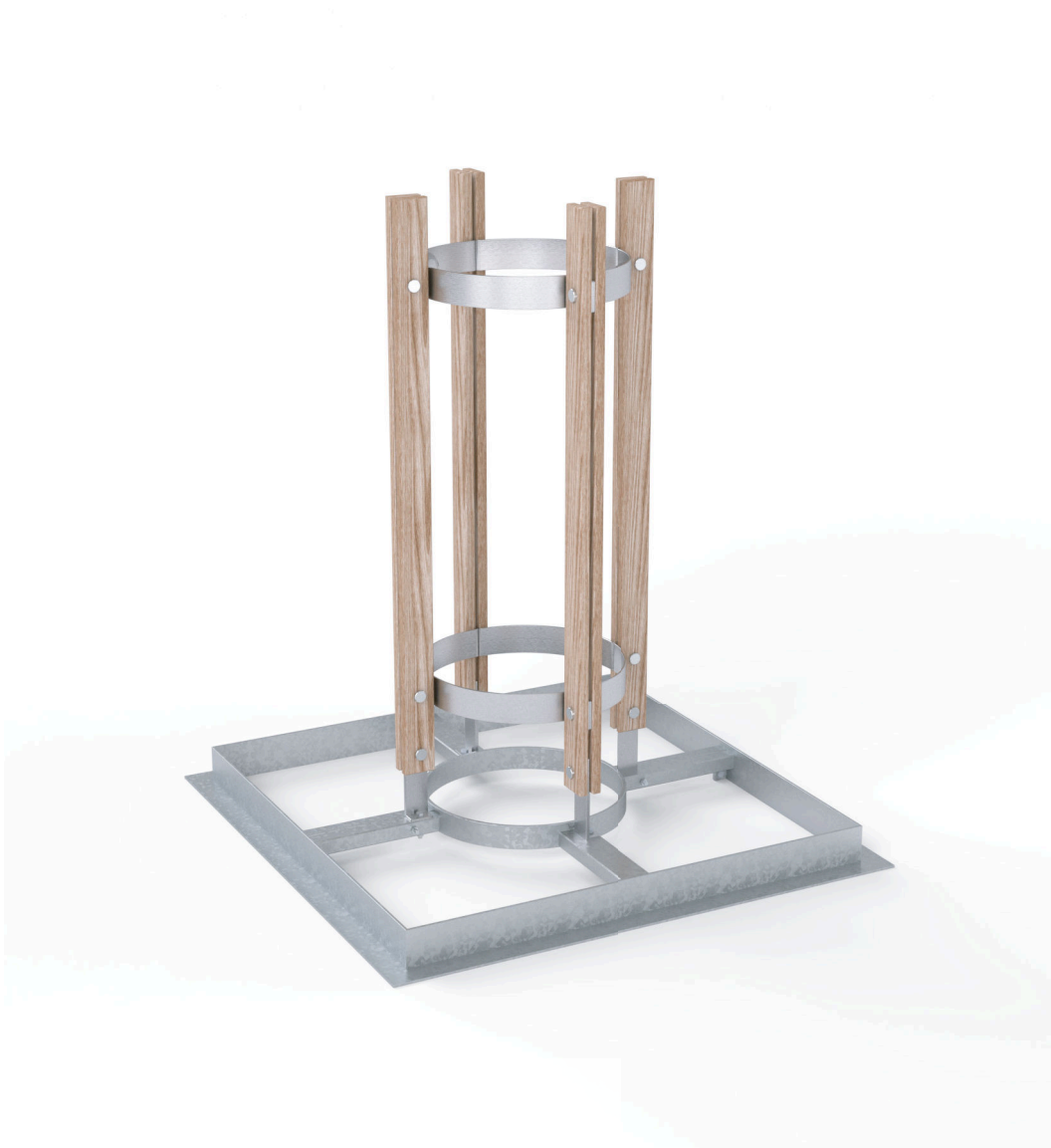

Chronos Tree Guard & Base

OPERATION & MAINTENANCE MANUAL

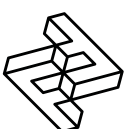

Introduction

Design

Design, shop drawings and development by Factory Furniture Ltd.

Manufacture

Factory Furniture manufactured components. Products are assembled in Factory workshops, checked and dispatched ready for installation. Replacement products or components thereof should be ordered direct from Factory Furniture Ltd.

Copyright

The design copyright for the product and drawing copyright remains the sole property of Factory Furniture Ltd.

General Specifications

Chronos Tree Guard & Base

Metric length 1330mm | width 1330mm | height 1500mm*

Imperial length 4' 4½" | width 4' 4½" | height 4' 11"

* Not including +100mm below ground level

Approx Weight 101kg

Materials & Finishes

Slats

- Manufactured from FSC® certified tropical hardwood (other FSC timber options available).
- Profiled and left untreated as standard (oil or microporous woodstain treatment available on request)
- 8 no. slats total bolted to quadrants using M12 threaded rods and aluminium endcaps - 3 no. fixing points per slat



Frame

- 8 no. quadrants and 4 no. feet manufactured from stainless steel - satin polished finish
- 2 no. stainless steel 'eyes' for securing tree welded to upper quadrants
- 4 no. feet allowing treeguard to be bolted to base (1 no. fixing point per foot)

Base

- Base manufactured from mild steel with a hot dipped galvanised finish
- Base separates into two halves for ease of installation. Once in place the two halves of the base are bolted together (4 no. fixing points)
- Base is root fixed 100mm below ground level

General Maintenance

(Recommended Schedule & Guidelines)

Daily/Weekly/Monthly (or as adopted)

Visual checks of timber table slats and frame - check all items for superficial or physical damage.

Three Monthly

Clean all items as detailed below check all fixings are seated correctly; inspect timber for serious damage and splinters.

Six Monthly

Secure all fixings; full clean as detailed below; check that table and benches are firmly secured to the ground

Specific Maintenance Details

FSC Timber

Clean with a stiff brush once per year, especially in more exposed locations, in order to prevent a verdigris type build up on the timber surface. Ideally this should be completed in early spring. During the cleaning stage, all exposed timber surfaces should be inspected for splits and splinters. Any splinters and graffiti should be removed and the surface sanded with 100 grit sandpaper in order to remove any uneven / sharp edges or surfaces.

During the first few months after installation the tannin naturally occurring in the timber may leach out and cause a brown staining on the bases. This may be removed with a light solution of household bleach and water.

Stainless Steel (polished stainless steel only)

Clean as required, but at least every three months, using a stainless steel polish and a lint free cloth. To remove ground in dirt, a stainless steel finishing pad may be required.

Galvanised

For general cleaning using a damp cloth and warm soapy water only. Scourers and abrasive cleaners are NOT suitable for this type of finish and may damage it. Before using any cleaning agents to remove graffiti etc. try on a small, inconspicuous area first to avoid causing more unsightly damage.

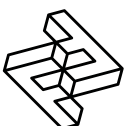

Repairs

FSC Timber

For light damage, please see section on specific maintenance details above. For instances of heavy damage, the timber item should be replaced. Please order against the part number reference in the reordering section towards the end of this manual.

Stainless Steel

Light damage (surface scratches etc.) can be removed using an emery pad (240 grit) and freeing oil such as 'WD40'. Care should be taken to follow the direction of the brushing grain. It is recommended that a trial repair be carried out on an unimportant surface first. No corrosive cleaners or other abrasives should be used. Any contamination, particularly carbon steel scuffs from vehicles, should be quickly removed to avoid corrosion

Galvanised Surfaces

For light damage to hot dipped galvanised finishes repair using a high performance cold galvanising zinc spray (70% zinc or above). Spray application should be carried out in accordance with approved methods detailed by the product manufacturer. Please note that it is advisable to use professional painters to achieve best results when touching up larger areas.

Heavy Damage

In the event of serious damage to any component, replacements should be ordered from Factory Furniture Ltd. In this event (or if the product needs to be disassembled for any reason), please contact Factory Furniture for detailed technical advice.

Installation Instructions

All installation works to be carried out by competent personnel - install as complete unit.

Chronos Tree Guard & Grille (sub-surface fix only)

1. For new tree planting dig appropriate sized hole for tree roots (approx. two times the width of the tree root ball and the same depth as the ball)
2. Position and correctly orientate base frame centrally over hole so that the top of the frame is at ground level. Ensure that frame is stable. For existing tree: base can either be lowered over tree fully assembled or for larger trees can be un-bolted and separated into two halves and re-assembled once in place. For bolting base assembly together use 2 no. M10x25mm bolts and nuts to secure tabs nearest surrounding frame and 2 no. M10x100mm bolts and nuts to bolt frame struts together
3. Check level of frame & re-instate ground level up to frame edge (ideally setting frame in concrete for stability).
4. Position tree in centre of hole and back fill over root ball. Do not back fill too far over the top of the root ball or this may cause the trunk bark to rot, damaging the tree. Lightly tread down backfill to secure tree.
5. Assemble treeguard if required using M12x55mm threaded rods and aluminium endcaps (tighten to 15Nm). To tighten endcaps use monkey wrench or similar wrapped in a rag to protect the endcap as it scratches easily.
6. Bolt treeguard assembly to base using M10x60mm bolts and nuts (tighten to 15Nm).
7. The tree guard fixing eyes can be used to secure the tree trunk if necessary.

IMPORTANT NOTE

Ensure that stainless steel is protected during site cutting of stone – contamination from disc cutters will produce corrosion on stainless steel components.

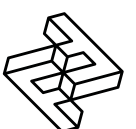

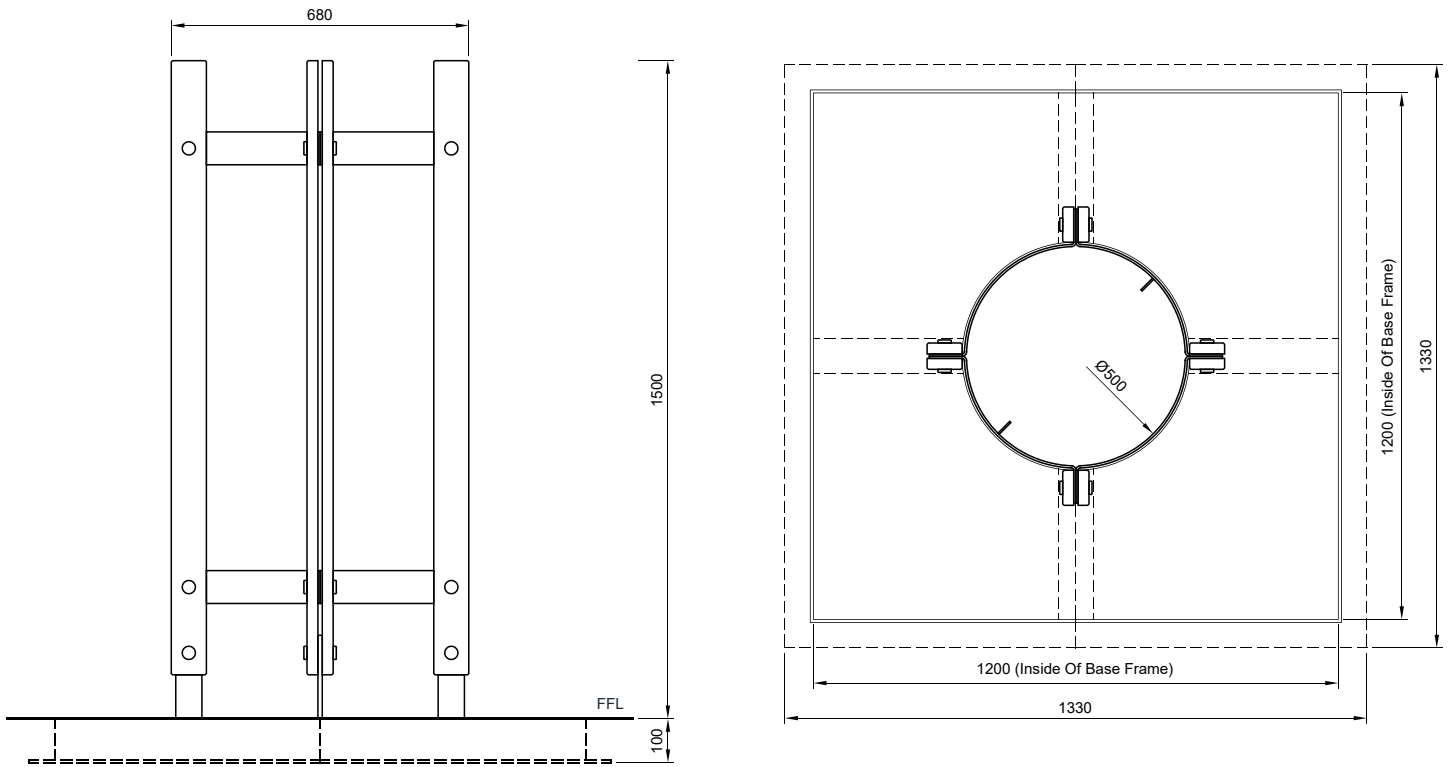

Chronos tree guard set out

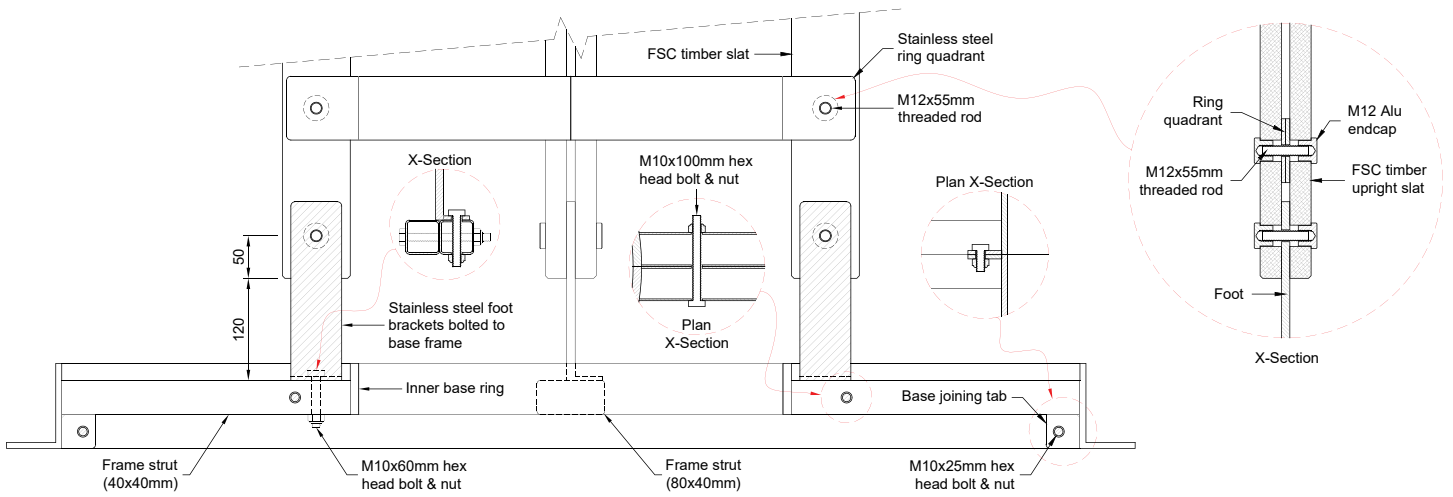

5 Pioneer Road, Faringdon,
 Oxfordshire SN7 7BU
 +44 (0)1367 242731
 hello@factoryfurniture.co.uk

factoryfurniture.co.uk

