

# FACTORY FURNITURE

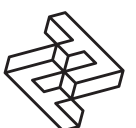

## Meet Table

TECHNICAL SHEET



## Solar Lighting Option

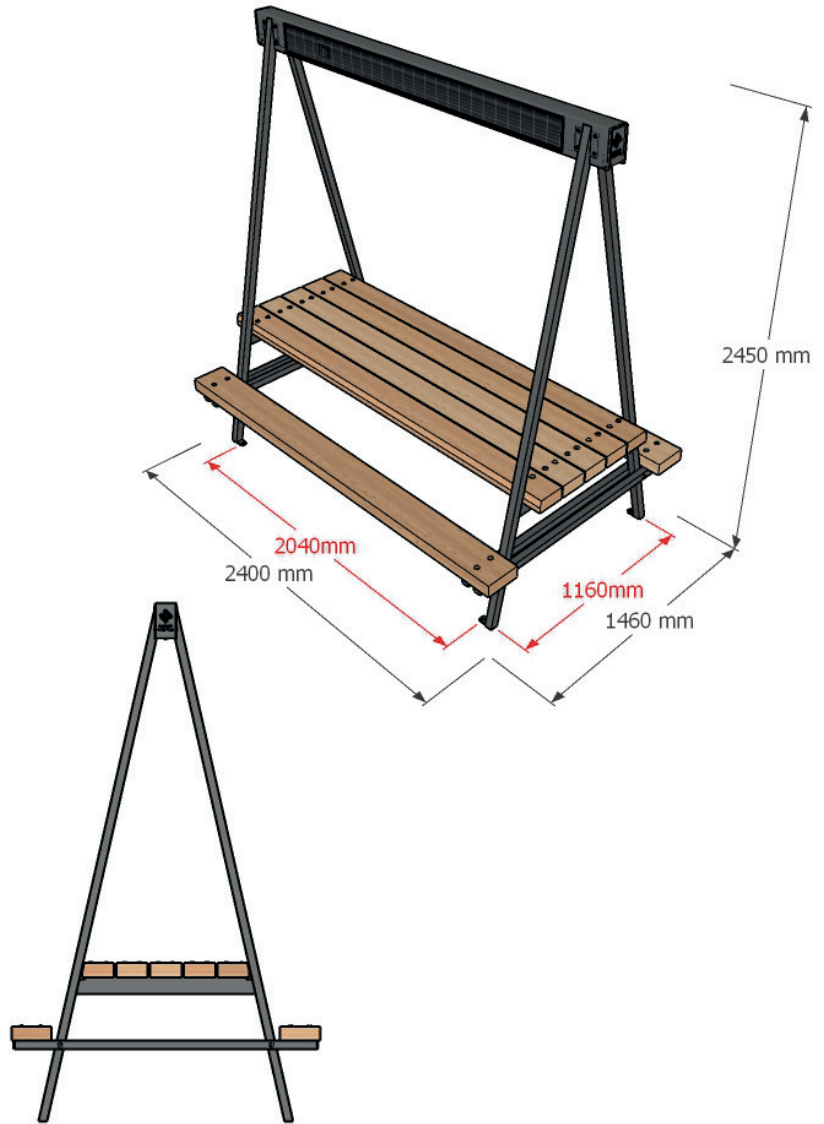
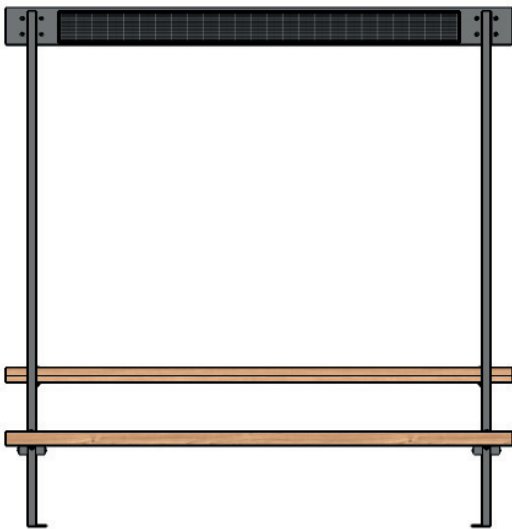

## Composition

Slats - FSC® certified softwood  
(Option for FSC certified  
hardwood available)

Frame - Mild steel

Power Options - Mains; Solar; Solar & phone charging



## Finishes

Timber - Tanalised sanded finish as standard  
Mild steel - Galvanised as standard (polyester  
powder-coated option available)\*

## Dimensions

Metric L - 2400mm | W - 1460mm | H - 2450mm

Imperial L - 7' 10½" | W - 4' 9½" | H - 8' ½"

## Approx weight

166kg

## Fixing centres

2040mm (6' 8½") x 1160mm (3' 9½")

## Fixing method

4 off resin fixed anchors

## Foundation

4 no. pads 400 x 400 x 400 mm in C20 concrete  
(recommendation only)

## Handling

Please observe health and safety lifting guidelines.  
A fork lift or crane will be required for off loading and  
positioning of this product

## Maintenance

Depends on usage and position. All elements will  
require annual cleaning. Galvanised and powder  
coated mild steel only require maintenance if  
damaged.

\*Please note that when a powder-coat is applied  
over a hot dip galvanised surface pinholing can  
occur in the surface finish - this is not  
considered a defect.

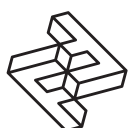

Solar Lighting & Phone  
Charging Option

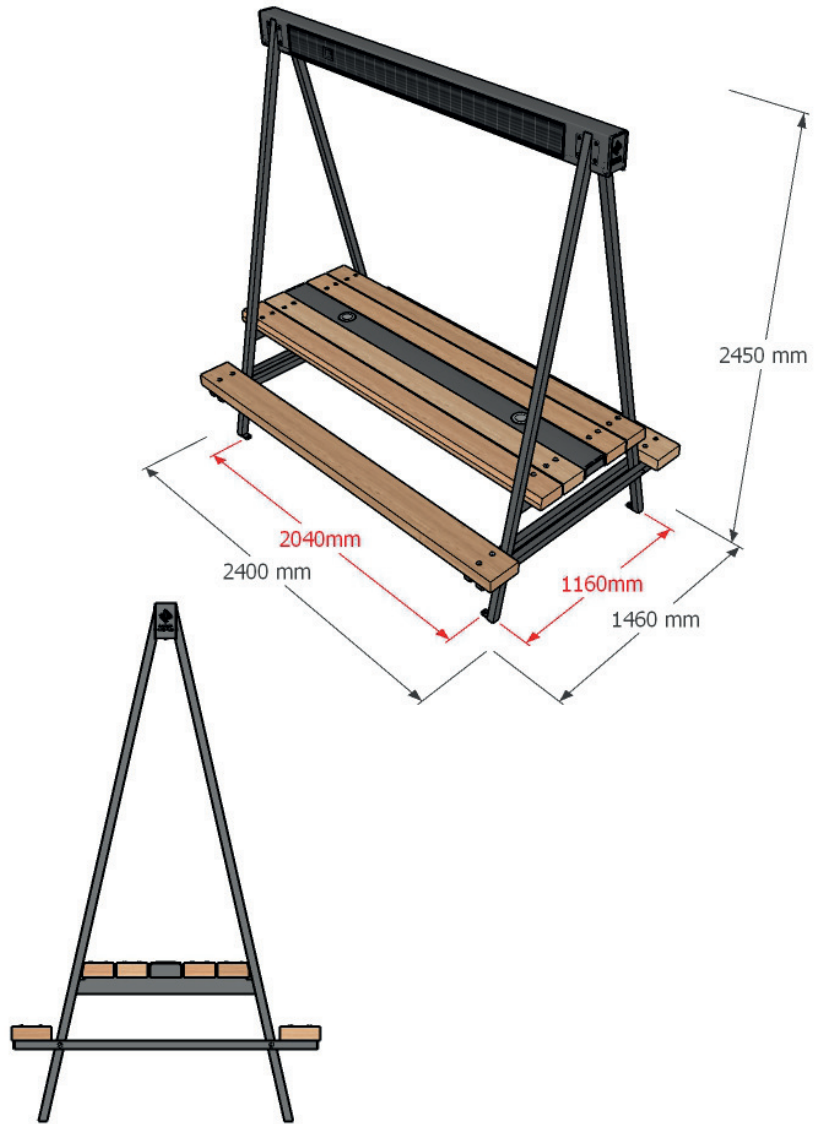
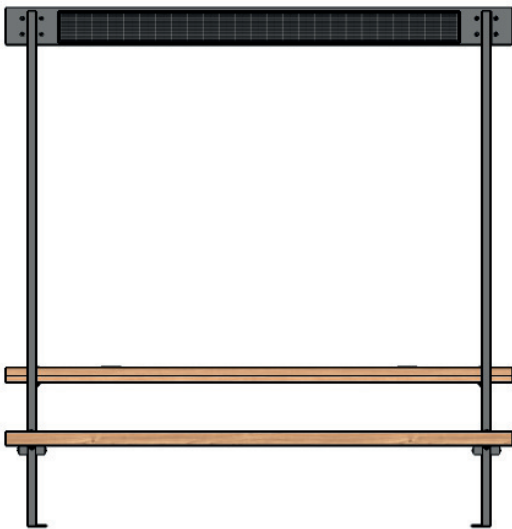

## Composition

Slats - FSC® certified softwood

(Option for FSC certified  
hardwood available)

Frame - Mild steel

Power Options - Mains; Solar; Solar & phone charging



## Finishes

Timber - Tanalised sanded finish as standard

Mild steel - Galvanised as standard (polyester  
powder-coated option available)\*

## Dimensions

Metric L - 2400mm | W - 1460mm | H - 2450mm

Imperial L - 7' 10½" | W - 4' 9½" | H - 8' ½"

## Approx weight

167kg

## Fixing centres

2040mm (6' 8½") x 1160mm (3' 9½")

## Fixing method

4 off resin fixed anchors

## Foundation

4 no. pads 400 x 400 x 400 mm in C20 concrete  
(recommendation only)

## Handling

Please observe health and safety lifting guidelines.  
A fork lift or crane will be required for off loading and  
positioning of this product

## Maintenance

Depends on usage and position. All elements will  
require annual cleaning. Galvanised and powder  
coated mild steel only require maintenance if  
damaged.

\*Please note that when a powder-coat is applied  
over a hot dip galvanised surface pinholing can  
occur in the surface finish - this is not  
considered a defect.

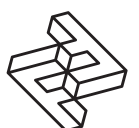

## Mains Lighting Option

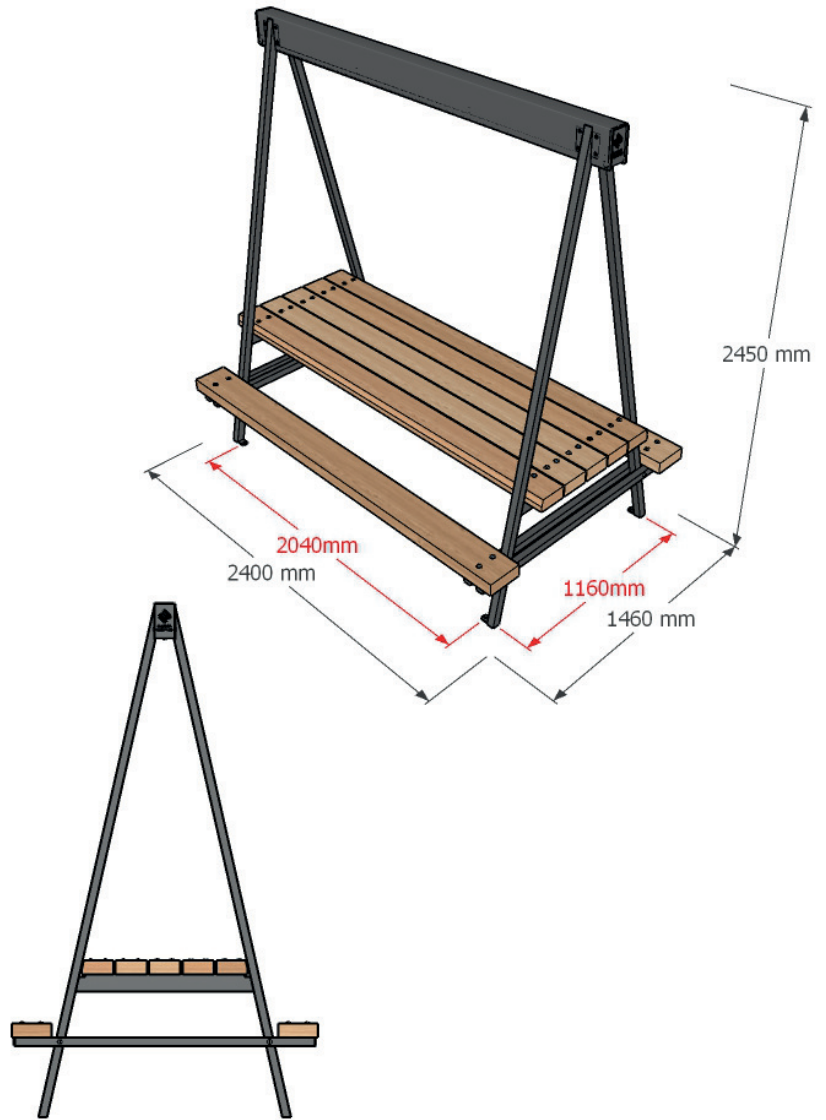
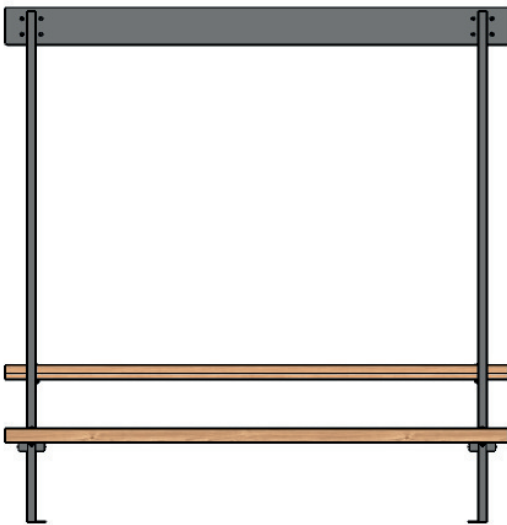

## Composition

Slats - FSC® certified softwood  
(Option for FSC certified  
hardwood available)

Frame - Mild steel

Power Options - Mains; Solar; Solar & phone charging



## Finishes

Timber - Tanalised sanded finish as standard

Mild steel - Galvanised as standard (polyester  
powder-coated option available)\*

## Dimensions

Metric L - 2400mm | W - 1460mm | H - 2450mm

Imperial L - 7' 10½" | W - 4' 9½" | H - 8' ½"

## Approx weight

161kg

## Fixing centres

2040mm (6' 8½") x 1160mm (3' 9½")

## Fixing method

4 off resin fixed anchors

## Foundation

4 no. pads 400 x 400 x 400 mm in C20 concrete  
(recommendation only)

## Handling

Please observe health and safety lifting guidelines.  
A fork lift or crane will be required for off loading and  
positioning of this product

## Maintenance

Depends on usage and position. All elements will  
require annual cleaning. Galvanised and powder  
coated mild steel only require maintenance if  
damaged.

\*Please note that when a powder-coat is applied  
over a hot dip galvanised surface pinholing can  
occur in the surface finish - this is not  
considered a defect.

