

FACTORY FURNITURE

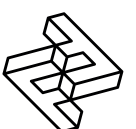

Quay Table

OPERATION & MAINTENANCE MANUAL



Introduction

Design

Design, shop drawings and development by Factory Furniture Ltd.

Manufacture

Factory Furniture manufactured components. Products are assembled in Factory workshops, checked and dispatched ready for installation. Replacement products or components thereof should be ordered direct from Factory Furniture Ltd.

Copyright

The design copyright for the product and drawing copyright remains the sole property of Factory Furniture Ltd.

General Specifications

Table

Metric L - 3000mm | W - 800mm | H - 755mm

Imperial L - 9' 10" | W - 2' 7½" | H - 2' 5½"

Approx Weight 249kg (140kg softwood option)

Fixing Centres 2400mm (7' 10½") x 550mm (1' 9½")

The Quay table can be combined with a couple of Quay benches to create an outdoor dining set

Detailed Material & Finish Specifications

Table Slats

- Manufactured from FSC® certified tropical hardwood (*option for FSC tanalised softwood*)
- Slats are profiled and left untreated as standard (*oil or microporous woodstain treatment available on request except for tanalised option*).
- Spacers and end caps in aluminum (*stainless steel available on request*) fastening 3 no. zinc-coated mild steel threaded tie rods per table top



Base Assembly

- Manufactured from mild steel with a hot dip galvanised finish. Bolted to slat assembly.
- Anchored to ground via 4 no. M10 x 130mm resin anchor studs and cap nuts per table.

General Maintenance

(Recommended Schedule & Guidelines)

Daily/Weekly/Monthly (or as adopted)

Visual checks of timber table slats and frame - check all items for superficial or physical damage.

Three Monthly

Clean all items as detailed below check all fixings are seated correctly; inspect timber for serious damage and splinters.

Six Monthly

Secure all fixings; full clean as detailed below; check that table and benches are firmly secured to the ground

Specific Maintenance Details

FSC Timber

Clean with a stiff brush once per year, especially in more exposed locations, in order to prevent a verdigris type build up on the timber surface. Ideally this should be completed in early spring. During the cleaning stage, all exposed timber surfaces should be inspected for splits and splinters. Any splinters and graffiti should be removed and the surface sanded with 100 grit sandpaper in order to remove any uneven / sharp edges or surfaces.

During the first few months after installation the tannin naturally occurring in the timber may leach out and cause a brown staining on the bases. This may be removed with a light solution of household bleach and water.

Galvanised & Polyester Powder Coated Surfaces

For general cleaning using a damp cloth and warm soapy water only. Scourers and abrasive cleaners are NOT suitable for this type of finish and may damage it. Before using any cleaning agents to remove graffiti etc. try on a small, inconspicuous area first to avoid causing more unsightly damage.

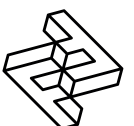

Repairs

FSC Timber

For light damage, please see section on specific maintenance details above. For instances of heavy damage, the timber item should be replaced. Please order against the part number reference in the reordering section towards the end of this manual.

Galvanised Surfaces

For light damage to hot dipped galvanised finishes repair using a high performance cold galvanising zinc spray (70% zinc or above). Spray application should be carried out in accordance with approved methods detailed by the product manufacturer. Please note that it is advisable to use professional painters to achieve best results when touching up larger areas.

Polyester Powder Coated Surfaces

For light damage (scratches, chips etc.) repair using touch-up paint to match original colour (available from Factory Furniture Ltd). Paint application should be carried out in accordance with approved methods detailed by the paint manufacturer. Please note that it is advisable to use professional painters to achieve best results when touching up larger areas. Products for respraying larger areas are available from Factory Furniture Ltd.

Heavy Damage

In the event of serious damage to any component, replacements should be ordered from Factory Furniture Ltd. In this event (or if the product needs to be disassembled for any reason), please contact Factory Furniture for detailed technical advice.

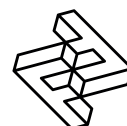

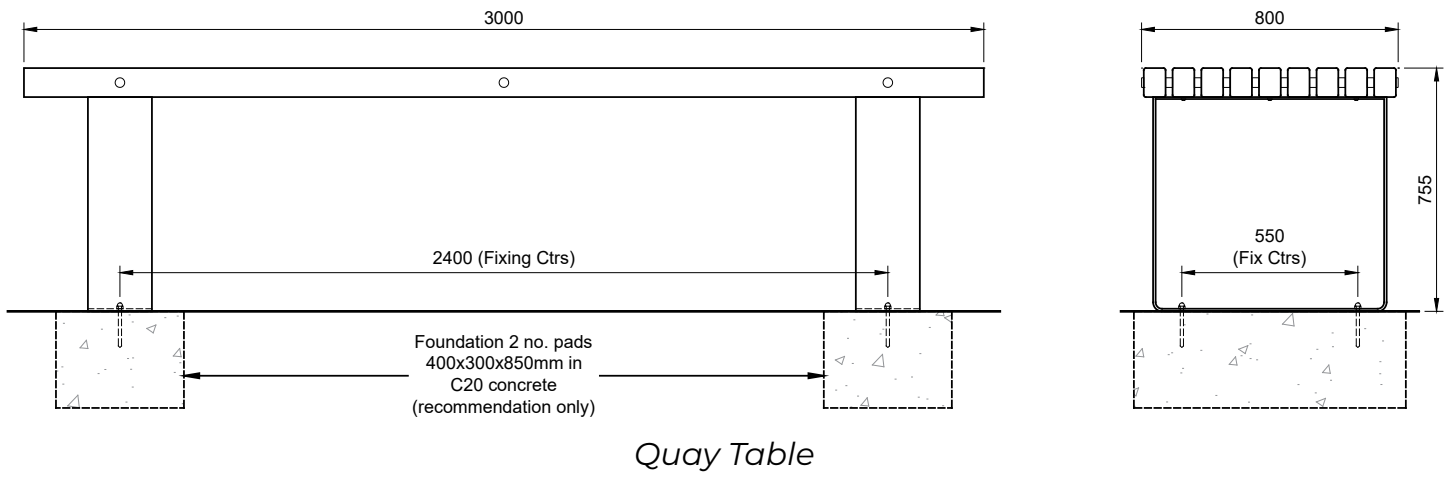

Installation Instructions

All installation works to be carried out by competent personnel - install as complete unit.

Quay Table

1. Install suitable foundation pads (see illustration) each with top face at ground level
2. Position table in correct orientation with bases centrally on foundation pads, then mark hole positions through base frame
3. Remove the table; drill holes $\text{\O}12\text{mm}$ x 125mm deep
4. Clear debris from holes
5. Fill the holes to within approximately 35mm from the top with Hilti HY150 resin (or similar). Lift the table (with threaded anchor rods / capnuts in place) and carefully lower the anchors into the holes, leave for two hours before using
6. Using a torque wrench, tighten nuts and washers over base frame to 30Nm to fasten down the table
7. Check level

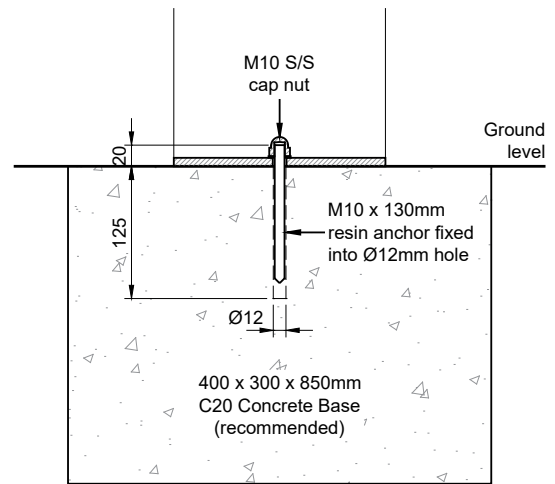

Base fix detail

IMPORTANT NOTE

Ensure that stainless steel is protected during site cutting of stone – contamination from disc cutters will produce corrosion on stainless steel components.

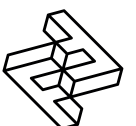

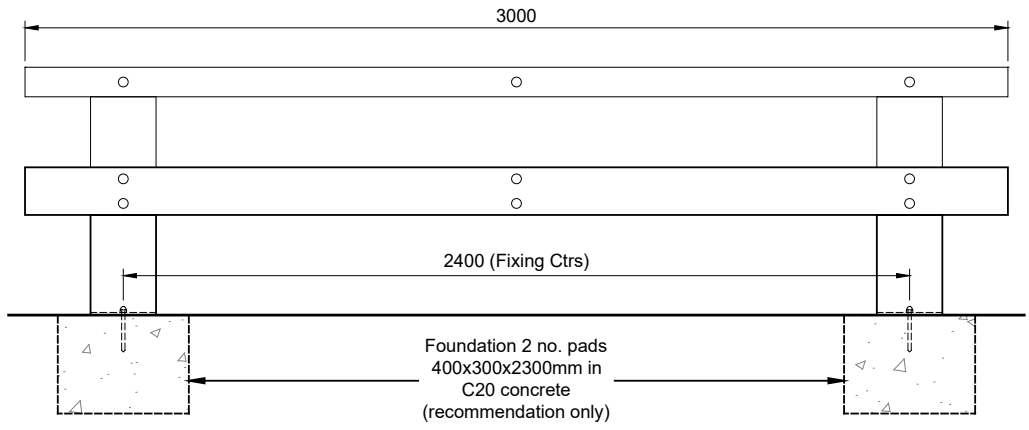

*Quay Picnic
Set*

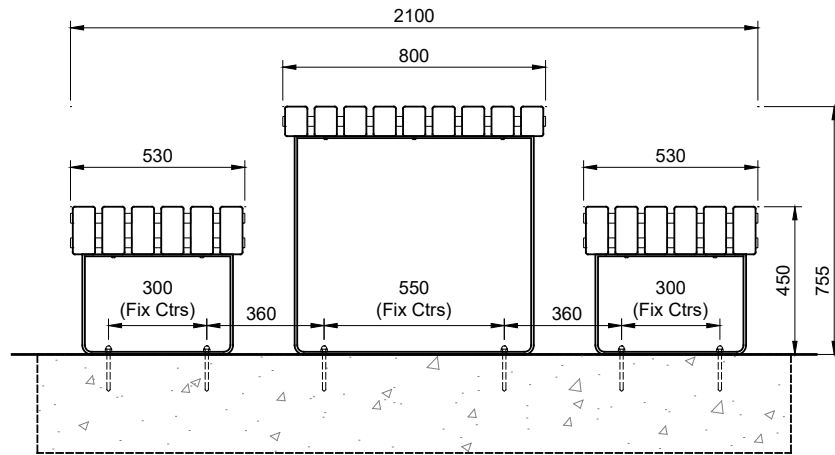

5 Pioneer Road, Faringdon,
Oxfordshire SN7 7BU
+44 (0)1367 242731
hello@factoryfurniture.co.uk

