

FACTORY FURNITURE

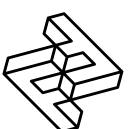

Skop Bench, Seat & Stool

OPERATION & MAINTENANCE MANUAL



Introduction

Design

Design, shop drawings and development by Factory Furniture Ltd.

Manufacture

Factory Furniture manufactured components. Products are assembled in Factory workshops, checked and dispatched ready for installation. Replacement products or components thereof should be ordered direct from Factory Furniture Ltd.

Copyright

The design copyright for the product and drawing copyright remains the sole property of Factory Furniture Ltd.

General Specifications

Bench

Metric length 2500mm | width 620mm | height 450mm

Imperial length 8' 2½" | width 2' ½" | height 1' 5½"

Approx Weight 78kg

Fixing Centres 2420mm (7' 11½") x 420mm (1' 4½")

Seat (with two backrests)

Metric length 2500mm | width 620mm | height 850mm

Imperial length 8' 2½" | width 2' ½" | height 2' 9½"

Approx Weight 93kg

Fixing Centres 2420mm (7' 11½") x 420mm (1' 4½")

Stool

Metric length 580mm | width 620mm | height 450mm

Imperial length 1' 11" | width 2' ½" | height 1' 5½"

Approx Weight 27kg

Fixing Centres 500mm (1' 7½") x 420mm (1' 4½")

Detailed Material & Finish Specifications

Seat Slats

- Manufactured from FSC® certified tropical hardwood or FSC certified oak (other FSC timber options available upon request).
- Profiled and left untreated as standard (oil or microporous woodstain treatment available on request).
- Supported on frame - attached with 4 no. fixing points each.

Back Rest (Skop 'seat' only)

- Slats are manufactured from FSC certified tropical hardwood or FSC oak to match seat slats (*other timber options available upon request*).
- Slats are profiled and left untreated as standard (*oil or microporous woodstain treatment available on request*). Each slat is attached to the back frame via 2 no. fixing points. Each back panel has 4 no. slats.
- Back rest frame manufactured from stainless steel - satin polished or polyester powder coated (*powder coat colour grey as standard or to customer specification*). Each back support is fixed to the seat via 10 no. fixing points.

Frame

- Manufactured from stainless steel rectangular section tubing - satin polished or polyester powder coated finishes (*powder coat colour grey as standard or to customer specification*).
- Anchored using 2 no. resin fixed M10 x 200mm threaded rods and cap nuts per base (*surface fix only*).

General Maintenance

(Recommended Schedule & Guidelines)

Daily/Weekly/Monthly (or as adopted)

Visual checks of seat top, back and bases - check all items for superficial or physical damage.

Three Monthly

Clean all items as detailed below check all fixings are seated correctly; inspect timber for serious damage and splinters.

Six Monthly

Secure all fixings; full clean as detailed below; check that perch is firmly secured to the ground.

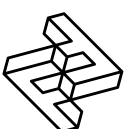

Specific Maintenance Details

FSC Timber

Clean with a stiff brush once per year, especially in more exposed locations, in order to prevent a verdigris type build up on the timber surface. Ideally this should be completed in early spring. During the cleaning stage, all exposed timber surfaces should be inspected for splits and splinters. Any splinters and graffiti should be removed and the surface sanded with 100 grit sandpaper in order to remove any uneven / sharp edges or surfaces.

During the first few months after installation the tannin naturally occurring in the timber may leach out and cause a brown staining on the bases. This may be removed with a light solution of household bleach and water.

Stainless Steel (polished stainless steel only)

Clean as required, but at least every three months, using a stainless steel polish and a lint free cloth. To remove ground in dirt, a stainless steel finishing pad may be required.

Polyester Powder Coated

For general cleaning using a damp cloth and warm soapy water only. Scourers and abrasive cleaners are NOT suitable for this type of finish and may damage it. Before using any cleaning agents to remove graffiti etc. try on a small, inconspicuous area first to avoid causing more unsightly damage.

Repairs

FSC Timber

For light damage, please see section on specific maintenance details above. For instances of heavy damage, the timber item should be replaced. Please order against the part number reference in the reordering section towards the end of this manual.

Stainless Steel

Light damage (surface scratches etc.) can be removed using an emery pad (240 grit) and freeing oil such as 'WD40'. Care should be taken to follow the direction of the brushing grain. It is recommended that a trial repair be carried out on an unimportant surface first. No corrosive cleaners or other abrasives should be used. Any contamination, particularly carbon steel scuffs from vehicles, should be quickly removed to avoid corrosion.

Polyester Powder Coated Surfaces

For light damage (scratches, chips etc.) repair using touch-up paint to match original colour (available from Factory Furniture Ltd). Paint application should be carried out in accordance with approved methods detailed by the paint manufacturer. Please note that it is advisable to use professional painters to achieve best results when touching up larger areas. Products for respraying larger areas are available from Factory Furniture Ltd.

Heavy Damage

In the event of serious damage to any component, replacements should be ordered from Factory Furniture Ltd. Should further assistance be required (or if the product needs to be disassembled for any reason), please contact Factory Furniture for detailed technical advice.

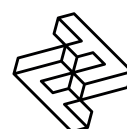

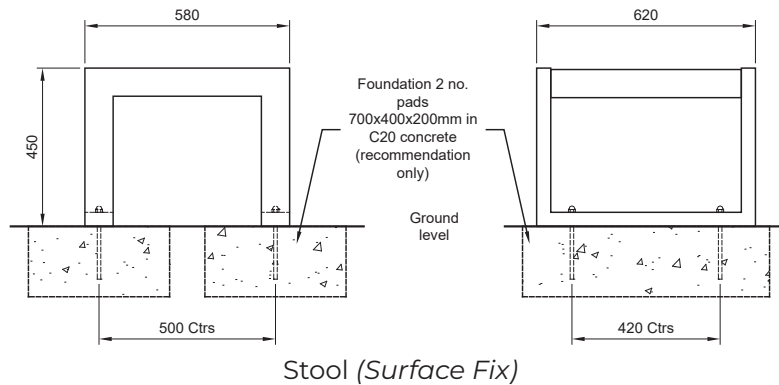
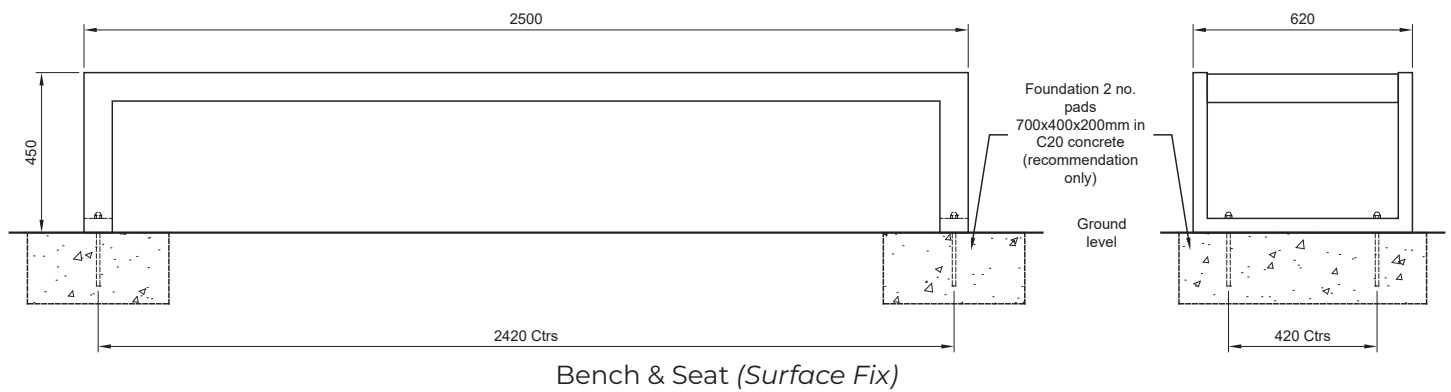

Installation Instructions

All installation works to be carried out by competent personnel - install as complete unit.

Skop Bench / Seat / Stool (Surface fix only)

1. Install suitable foundation pads (see illustration) each with top face at ground level
2. Position bench in correct orientation with bases centrally on foundation pads, then mark hole positions through base plates.
3. Remove the bench; drill holes $\varnothing 12\text{mm} \times 175\text{mm}$ deep
4. Clear debris from holes.
5. Fill the holes to within approximately 35mm from the top with Hilti HY150 resin (or similar). Lift the seat (with threaded anchor rods/capnuts in place) and carefully lower the anchors into the holes, leave for two hours before using.

6. Using a torque wrench, tighten nuts and washers over flange plates to 30Nm to fasten down the bench.
7. Check level

IMPORTANT NOTE

Ensure that stainless steel is protected during site cutting of stone – contamination from disc cutters will produce corrosion on stainless steel components.

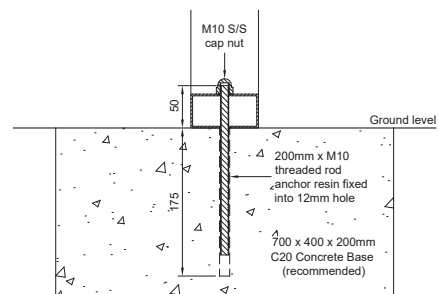

5 Pioneer Road, Faringdon,
Oxfordshire SN7 7BU
+44 (0)1367 242731
hello@factoryfurniture.co.uk

factoryfurniture.co.uk

