

FACTORY FURNITURE

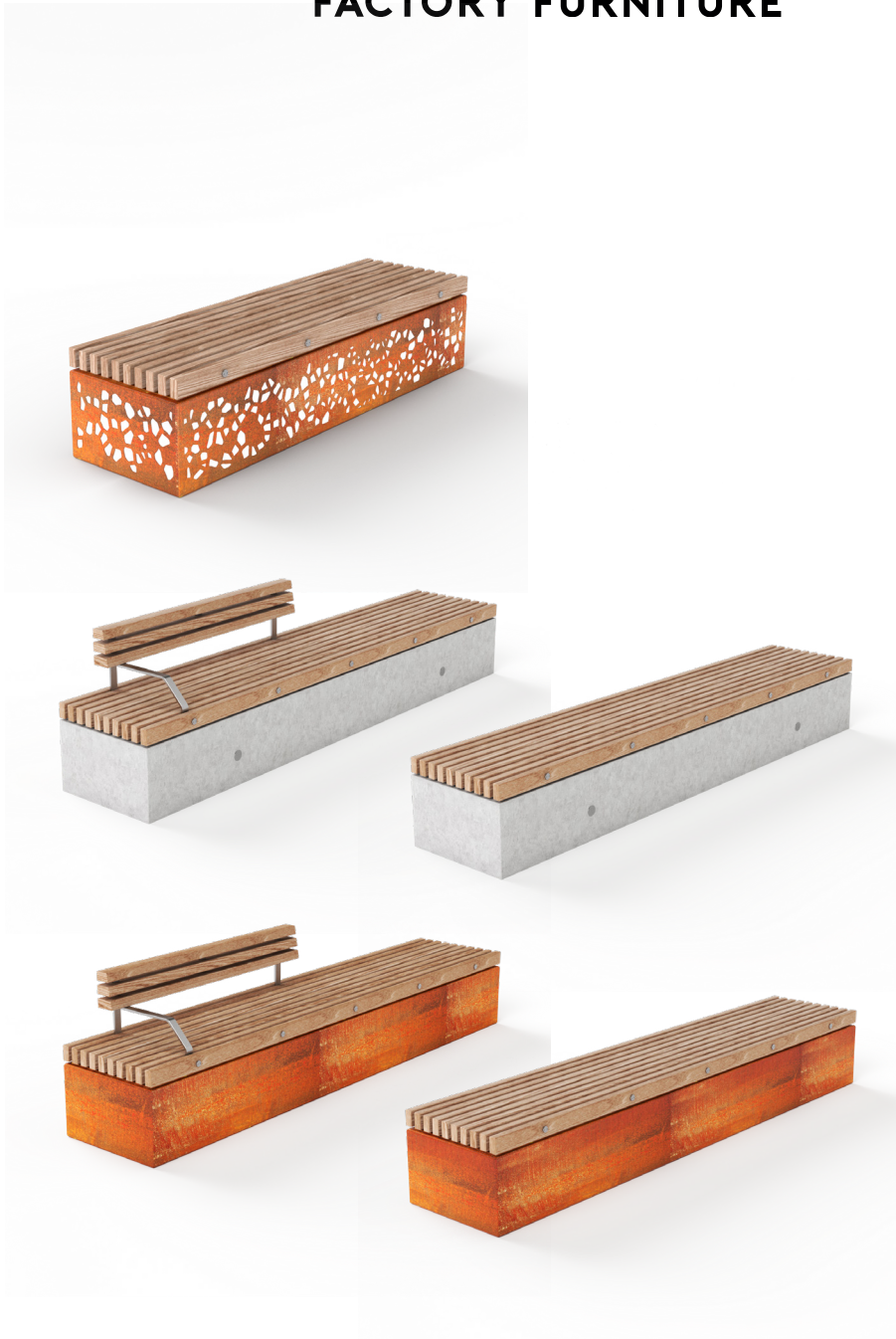

Soca Benches & Seats

OPERATION & MAINTENANCE MANUAL

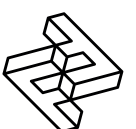

Introduction

Design

Design, shop drawings and development by Factory Furniture Ltd.

Manufacture

Factory Furniture manufactured components. Products are assembled in Factory workshops, checked and dispatched ready for installation. Replacement products or components thereof should be ordered direct from Factory Furniture Ltd.

Copyright

The design copyright for the product and drawing copyright remains the sole property of Factory Furniture Ltd.

General Specifications

Bench (Concrete base)

Metric L 3000mm | W 610mm | H 435mm

Imperial L 9' 10" | W 2' 0" | H 1' 5"

Approx Weight 1556kg

Fixing Centres N/A

Seat (Concrete base)

Metric L 3000mm | W 610mm | H 750mm

Imperial L 9' 10" | W 2' 0" | H 2' 5½"

Approx Weight 1579kg

Fixing Centres N/A

Bench (Galvanised steel base)

Metric L 3000mm | W 610mm | H 450mm

Imperial L 9' 10" | W 2' 0" | H 1' 5½"

Approx Weight 142kg

Fixing Centres 1710mm (5' 7½") x 500mm (1' 7½")

Seat (Galvanised steel base)

Metric L 3000mm | W 610mm | H 765mm

Imperial L 9' 10" | W 2' 0" | H 2' 6"

Approx Weight 166kg

Fixing Centres 1710mm (5' 7½") x 500mm (1' 7½")

Seat (Corten base)

Metric L 2000mm | W 610mm | H 450mm

Imperial L 6' 6½" | W 2' 0" | H 1' 5½"

Approx Weight 182kg

Fixing Centres 1500mm (4' 11") x 500mm (1' 7½")

Detailed Material & Finish Specifications

Bench / Seat Slat Assembly

- Manufactured from FSC® certified tropical hardwood (other FSC timber options available upon request)
- Profiled and left untreated as standard (oil or microporous woodstain treatment available on request)
- Slats assembled using aluminium endcaps and spacers and concealed zinc-coated mild steel threaded tie rods



Back & Armrest Assembly (Seat only)

- Slats manufactured from FSC certified tropical hardwood (other FSC timber options available upon request)
- Slats are profiled and left untreated as standard (oil or microporous woodstain treatment available on request). Slats fixed to backrest uprights to create back and armrest assembly
- Backrest uprights and armrest manufactured from stainless steel (satin polished).

Concrete Base Option

- Manufactured from exposed aggregate concrete (limestone, yellow granite, blue granite and black granite effects available - all shot peened). Surface is sealed to make it water repellent. Galvanised steel internal reinforcement.
- 4 no. lifting sockets included (M20) ***Lifting eyes not supplied***
- Bench slats supported on stainless steel brackets screwed to slats and bolted to concrete base

Steel Base Option

- Manufactured from galvanised steel with an all welded construction. Bases are hot dipped galvanised with the option for a polyester powder coated finish (grey as standard or as per customer specification)

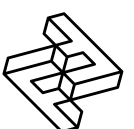

- Bases are bolted to slat assembly and anchored to ground using 4 no. zinc-coated M10 x 75mm sleeve anchors per bench / seat (2 no. per base)

Corten Base Option

- Manufactured from corten steel (all welded construction). Removable slat assembly bolted to base.
- LED rope light (warm white as standard) mounted within base provides night-time illumination on all sides through removable white frosted polycarbonate diffuser panels mounted behind walls of corten base.
- Base anchored to ground using 4 no. zinc-coated M10 x 75mm sleeve anchors.

General Maintenance

(Recommended Schedule & Guidelines)

Daily/Weekly/Monthly (or as adopted)

Visual checks of seat top, back and bases - check all items for superficial or physical damage.

Three Monthly

Clean all items as detailed below check all fixings are seated correctly; inspect timber for serious damage and splinters.

Six Monthly

Secure all fixings; full clean as detailed below; check that seat/bench is firmly secured to the ground.

Specific Maintenance Details

FSC Timber

Clean with a stiff brush once per year, especially in more exposed locations, in order to prevent a verdigris type build up on the timber surface. Ideally this should be completed in early spring. During the cleaning stage, all exposed timber surfaces should be inspected for splits and splinters. Any splinters and graffiti should be removed and the surface sanded with 100 grit sandpaper in order to remove any uneven / sharp edges or surfaces.

During the first few months after installation the tannin naturally occurring in the timber may leach out and cause a brown staining on the bases. This may be removed with a light solution of household bleach and water.

Corten Steel & Stainless Steel (polished stainless steel only)

Clean as required, but at least every three months, using a stainless steel polish and a lint free cloth. To remove ground in dirt, a stainless steel finishing pad may be required.

Polyester Powder Coated & Galvanised

For general cleaning using a damp cloth and warm soapy water only. Scourers and abrasive cleaners are NOT suitable for this type of finish and may damage it. Before using any cleaning agents to remove graffiti etc. try on a small, inconspicuous area first to avoid causing more unsightly damage.

Granite / Concrete

Clean with a stiff brush once per year, especially in more exposed locations, in order to prevent a verdigris type build up on the surface. Ideally, this should be completed in early spring.

Repairs

FSC Timber

For light damage, please see section on specific maintenance details above. For instances of heavy damage, the timber item should be replaced. Please order against the part number reference in the reordering section towards the end of this manual.

Stainless Steel

Light damage (surface scratches etc.) can be removed using an emery pad (240 grit) and freeing oil such as 'WD40'. Care should be taken to follow the direction of the brushing grain. It is recommended that a trial repair be carried out on an unimportant surface first. No corrosive cleaners or other abrasives should be used. Any contamination, particularly carbon steel scuffs from vehicles, should be quickly removed to avoid corrosion.

Polyester Powder Coated & Galvanised Surfaces

For light damage (scratches, chips etc.) repair using touch-up paint to match original colour (available from Factory Furniture Ltd). Paint application should be carried out in accordance with approved methods detailed by the paint manufacturer. Please note that it is advisable to use professional painters to achieve best results when touching up larger areas. Products for respraying larger areas are available from Factory Furniture Ltd.

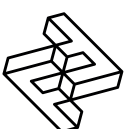

Corten Steel

There is no need to repair light damage (scratches, chips etc.) to the rust coloured layer on the surface of the Corten steel. This layer will naturally reform within a short period of time in an external environment.

Heavy Damage

In the event of serious damage to any component, replacements should be ordered from Factory Furniture Ltd. Should further assistance be required (or if the product needs to be disassembled for any reason), please contact Factory Furniture for detailed technical advice.

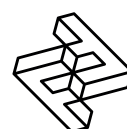

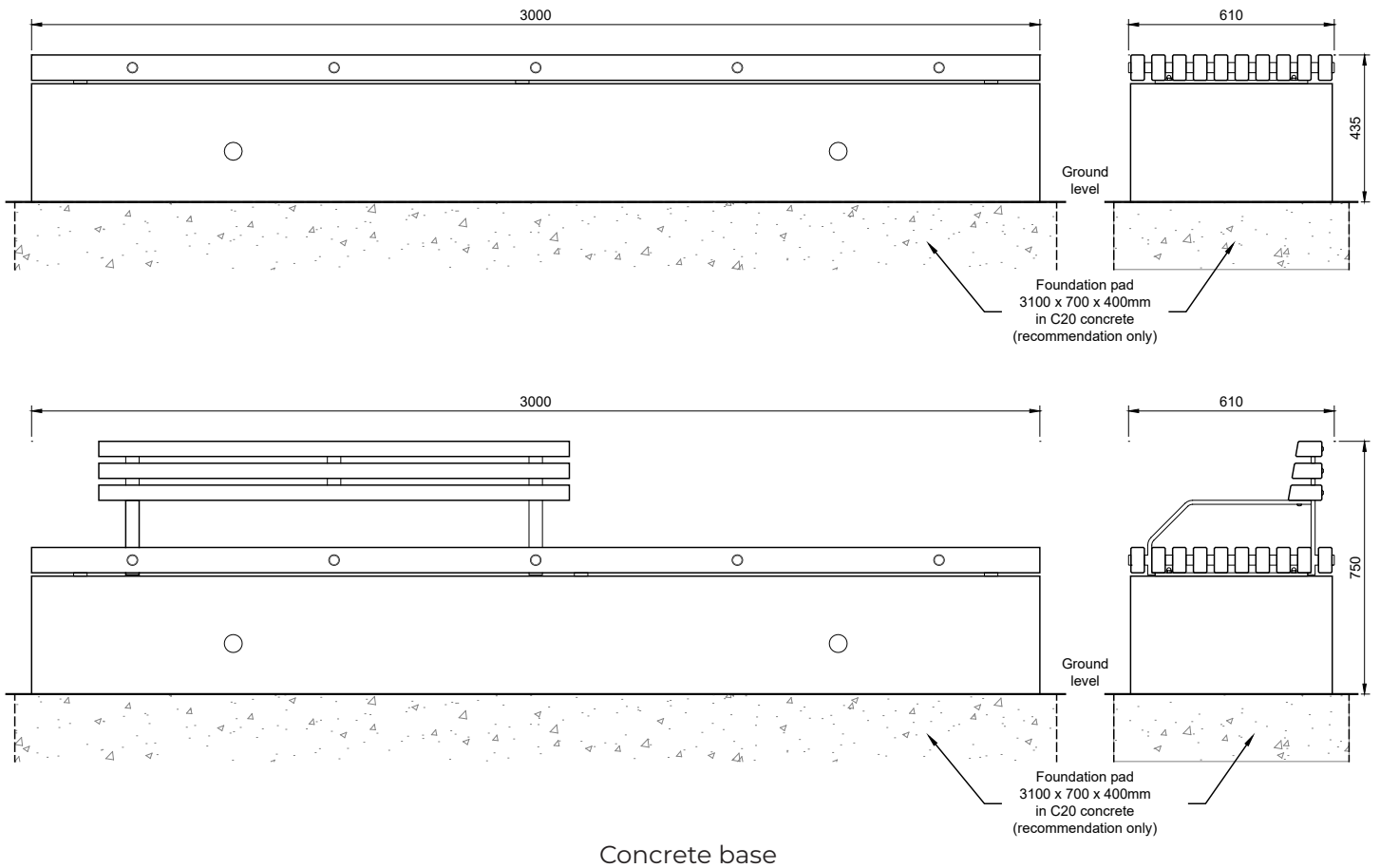

Concrete base

Installation Instructions

All installation works to be carried out by competent personnel - install as complete unit.

Soca Bench / Seat (Concrete Base)

1. Install suitable foundation pad (see illustration) top face at ground level. Remove any debris from proposed seating location.
2. Position concrete base centrally onto foundation pad - 4 no. lifting sockets included to aid lifting and positioning (M20) ****Lifting eyes not supplied****
3. Check level and screw in lifting eye dust covers.
4. Position timber bench / seat assembly centrally onto concrete base; mark hole positions through base brackets.
5. Remove bench / seat assembly
6. Drill holes in base $\varnothing 12\text{mm} \times 110\text{mm}$ deep*

7. Clear debris from holes.
8. Fill the holes to within approximately 30mm from the top with a styrene-free injection resin. Lift the bench / seat assembly (with M8 x 110mm resin anchor / M8 capnuts in place) and carefully lower the anchors into the holes, leave for two hours* before proceeding.
9. Using a torque wrench, tighten M8 nuts to 10Nm* to fasten down the bench / seat assembly.
*Or as manufacturer's recommendations.

IMPORTANT NOTE

Ensure that stainless steel is protected during site cutting of stone – contamination from disc cutters will produce corrosion on stainless steel components.

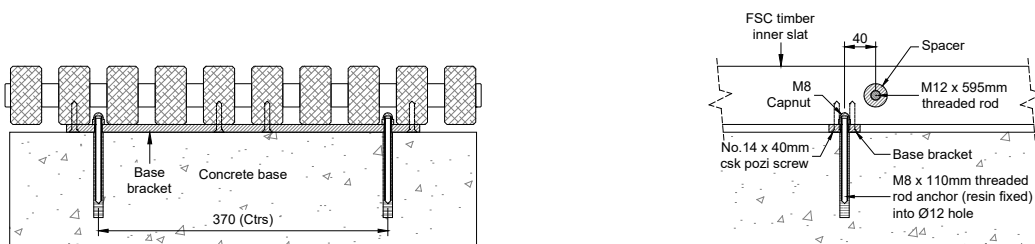

Fixing Detail

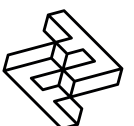

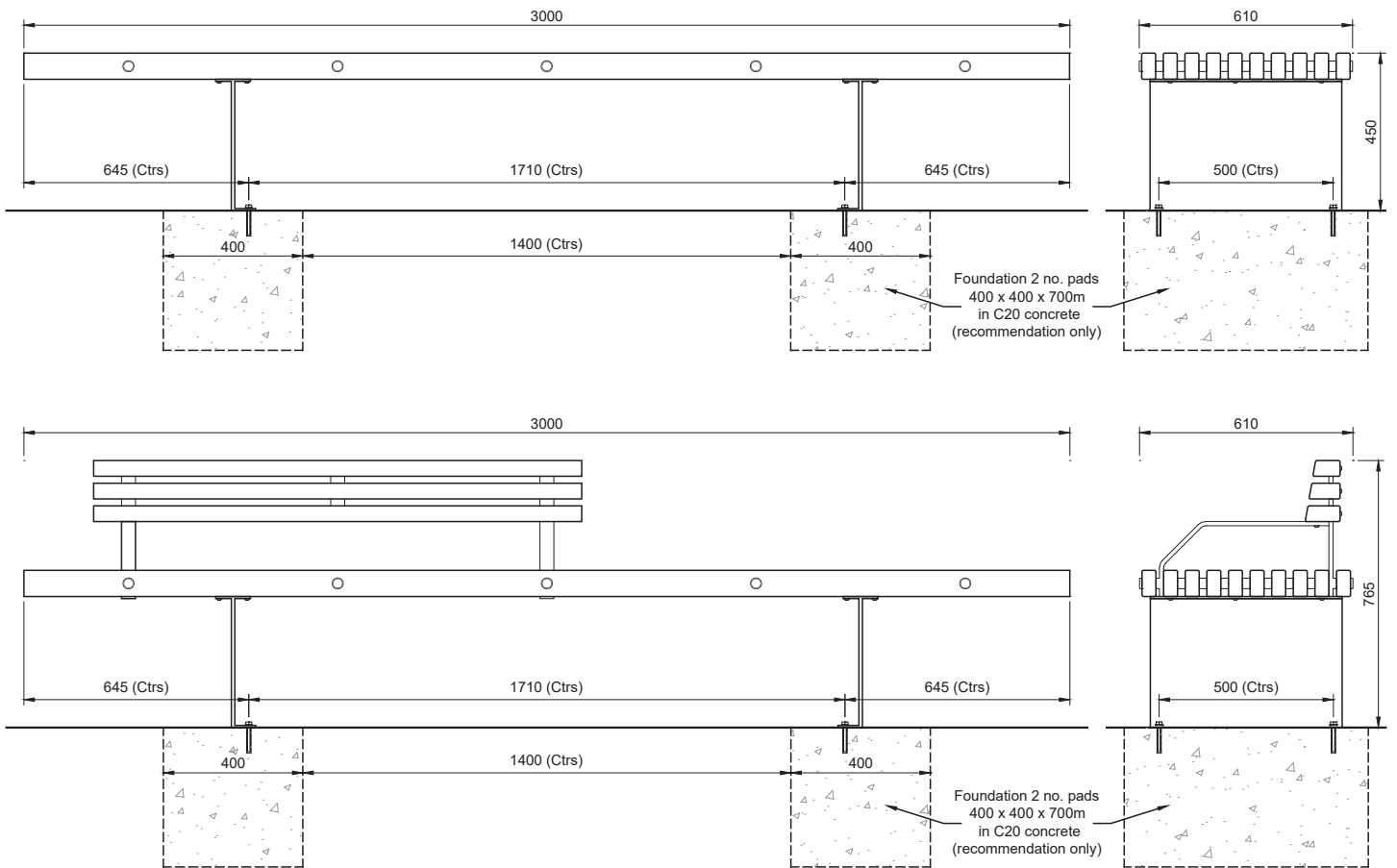

Steel Bases (Surface Fix)

Installation Instructions

All installation works to be carried out by competent personnel - install as complete unit.

Soca Bench / Seat (Steel Base) (Surface fix only)

1. Install suitable foundation pads (see illustration) with top faces at ground level
2. Position bench / seat so bases are central on foundation pads then mark hole positions onto pads
3. Remove the bench / seat; drill holes $\text{\O}12\text{mm}$ x 75mm deep (or as bolt manufacturer's recommendations)
4. Clear debris from holes

5. Reposition bench / seat and fix to foundation pads using 4 no. zinc-coated M10 x 75mm sleeve anchors tightened to 50Nm (or as per manufacturer's instruction). Ensure bench / seat remains level during fixing process
6. Check level & re-instate ground level

IMPORTANT NOTE

Ensure that stainless steel is protected during site cutting of stone – contamination from disc cutters will produce corrosion on stainless steel components.

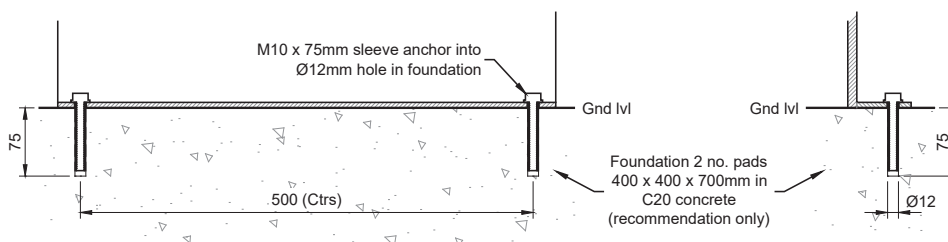

Fixing Detail

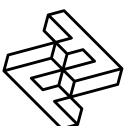

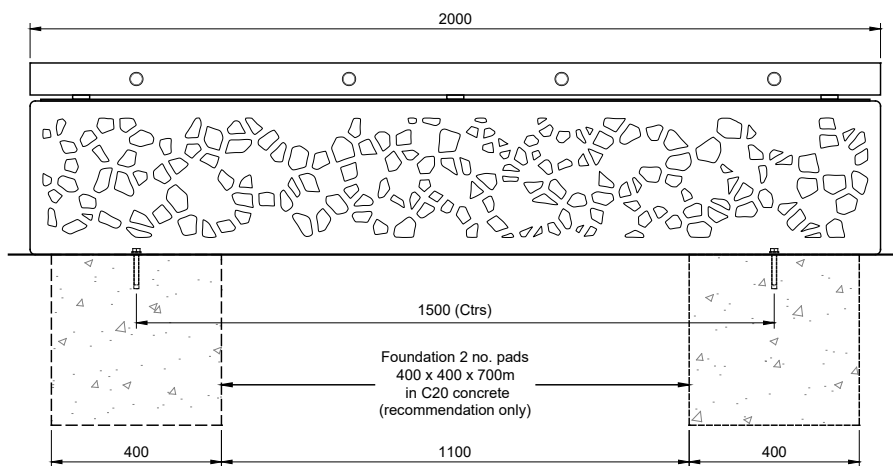

Corten Base (Surface Fix)

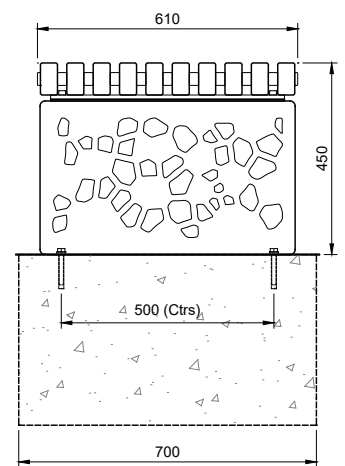

Installation Instructions

All installation works to be carried out by competent personnel - install as complete unit.

Soca Bench (Corten Base) (Surface fix only)

1. Install suitable foundation pads (see illustration) with top faces at ground level
2. If necessary remove slat assembly (6 no. bolts visible between slats) to access base fixing holes within base
3. Position base so that it's central on foundation pads then mark hole positions onto pads
4. Remove the base; drill holes $\text{\O}12\text{mm}$ x 75mm deep (or as bolt manufacturer's recommendations)
5. Clear debris from holes
6. Reposition base and fix to foundation pads using 4 no. zinc-coated M10 x 75mm sleeve anchors tightened to 50Nm (or as per manufacturer's instruction). Ensure bench remains level during fixing process
7. Check level & re-instate ground level if required
8. At this stage LED lighting on underside of slat assembly can be connected to the supply by a suitably qualified electrician
9. Re-position and bolt down slat assembly

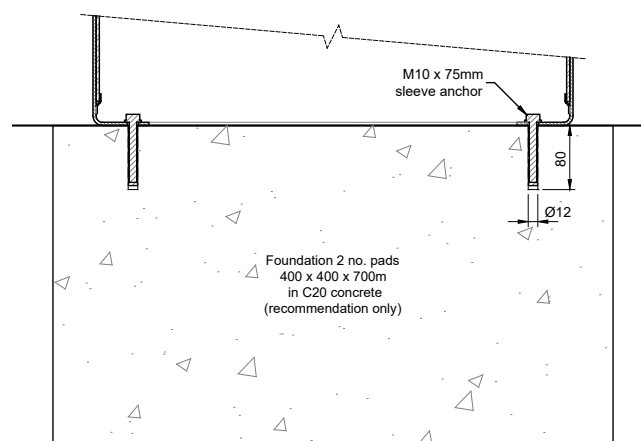

Fixing Detail

5 Pioneer Road, Faringdon,
Oxfordshire SN7 7BU
+44 (0)1367 242731
hello@factoryfurniture.co.uk

factoryfurniture.co.uk

