

FACTORY FURNITURE

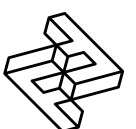

Sonobe Bench

OPERATION & MAINTENANCE MANUAL



Introduction

Design

Design, shop drawings and development by Factory Furniture Ltd.

Manufacture

Factory Furniture manufactured components. Products are assembled in Factory workshops, checked and dispatched ready for installation. Replacement products or components thereof should be ordered direct from Factory Furniture Ltd.

Copyright

The design copyright for the product and drawing copyright remains the sole property of Factory Furniture Ltd.

General Specifications

Bench

Metric L 795mm | width 685mm | height 450mm
Imperial length 2' 7½" | width 2' 3" | height 1' 5½"

Approx Weight 52kg

Fixing Centres 345mm (1' 1½") x 270mm (10½")

Concrete Bench

Metric L 785mm | width 685mm | height 450mm
Imperial length 2' 7" | width 2' 3" | height 1' 5½"

Approx Weight 287kg

Material & Finish

Bench Slat Panels

- Manufactured from FSC® softwood (other FSC options available incl. tropical hardwood (e.g. Cumaru) or Shou Sugi Ban (charred))
- Slats are profiled and left untreated as standard (oil or microporous woodstain treatment available on request).
- Slats screwed onto galvanised mild steel rails producing two separate slat panels (top and front). Slat panels are bolted onto bench body (4 no. fixing points per panel). Top slat panel can be removed to enable fixing of bench to ground.



Bench Body

- Manufactured from mild steel; featuring an all welded construction and a hot dip galvanised finish as standard (polyester powder-coated option available*)
- Anchored to ground via 3 no. M10 x 75mm sleeve anchor per bench.

Please note that when a powder-coat is applied to a hot dip galvanised surface pinholing can occur in the surface finish - this is not considered a defect.

Concrete Option

- Seat material - Smooth or exposed aggregate concrete. A variety of stone effects are available in either smooth, shot peened, honed or polished finishes. (Please refer to 'Concrete Finishes' specification document for further details). Surface is smoothed and sealed to make it water repellent
- Internal reinforcement - Galvanised mild steel frame

General Maintenance

(Recommended Schedule & Guidelines)

Daily/Weekly/Monthly (or as adopted)

Visual checks of seat top, back and bases - check all items for superficial or physical damage.

Three Monthly

Clean all items as detailed below check all fixings are seated correctly; inspect timber for serious damage and splinters.

Six Monthly

Secure all fixings; full clean as detailed below; check that bench is firmly secured to the ground.

Specific Maintenance Details

FSC Timber

Clean with a stiff brush once per year, especially in more exposed locations, in order to prevent a verdigris type build up on the timber surface. Ideally this should be completed in early spring. During the cleaning stage, all exposed timber surfaces should be inspected for splits and splinters. Any splinters and graffiti should be removed and the surface sanded with 100 grit sandpaper in order to remove any uneven / sharp edges or surfaces.

During the first few months after installation the tannin naturally occurring in the timber may leach out and cause a brown staining on the bases. This may be removed with a light solution of household bleach and water.

Galvanised & Polyester Powder Coated

For general cleaning using a damp cloth and warm soapy water only. Scourers and abrasive cleaners are NOT suitable for this type of finish and may damage it. Before using any cleaning agents to remove graffiti etc. try on a small, inconspicuous area first to avoid causing more unsightly damage.

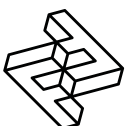

Granite / Concrete

Clean with a stiff brush once per year, especially in more exposed locations, in order to prevent a verdigris type build up on the surface. Ideally, this should be completed in early spring.

Repairs

FSC Timber

For light damage, please see section on specific maintenance details above. For instances of heavy damage, the timber item should be replaced. Please order against the part number reference in the reordering section towards the end of this manual

Galvanised Surfaces

For light damage to hot dipped galvanised finishes repair using a high performance cold galvanising zinc spray (70% zinc or above). Spray application should be carried out in accordance with approved methods detailed by the product manufacturer. Please note that it is advisable to use professional painters to achieve best results when touching up larger areas

Polyester Powder Coated Surfaces

For light damage (scratches, chips etc.) repair using touch-up paint to match original colour (available from Factory Furniture Ltd). Paint application should be carried out in accordance with approved methods detailed by the paint manufacturer. Please note that it is advisable to use professional painters to achieve best results when touching up larger areas. Products for respraying larger areas are available from Factory Furniture Ltd.

Heavy Damage

In the event of serious damage to any component, replacements should be ordered from Factory Furniture Ltd. Should further assistance be required (or if the product needs to be disassembled for any reason), please contact Factory Furniture for detailed technical advice.

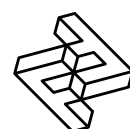

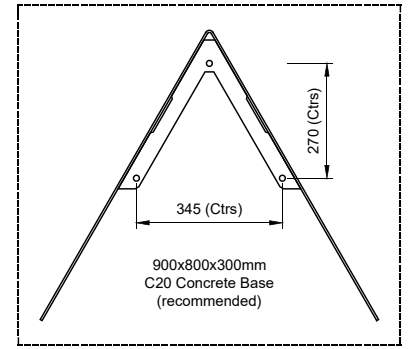
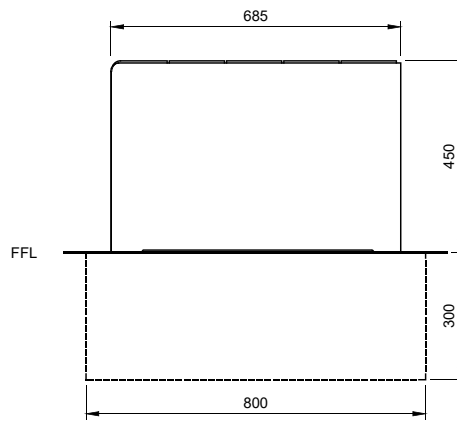
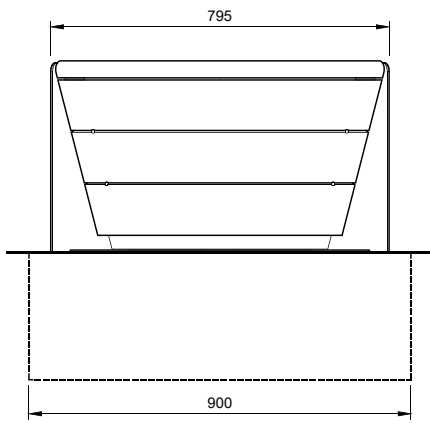

Installation Instructions

All installation works to be carried out by competent personnel - install as complete unit.

Sonobe Bench

1. Install suitable foundation pads (see illustrations) each with top face at ground level. When combining more than one bench, foundation pad should be at least 50mm larger on all sides than overall footprint of combined benches.
2. Remove top slat panel to allow access to base fixing plate beneath. Top slat panel is fixed to bench body using 4 off M8 cap screws (see X-Section illustration below)

3. Position bench in correct orientation with outer footprint of bench centrally on foundation pad(s); then mark hole positions through base plate.
4. Remove bench; drill holes - $\varnothing 12\text{mm} \times 80\text{mm}$ deep (or as manufacturer's recommendations).
5. Clear debris from holes.
6. Reposition bench unit and fix to foundation pad using 3 no. zinc-coated M10 x 75mm sleeve anchors tightened to 50Nm (or as per manufacturer's instruction). Ensure bench remains level during fixing process.
7. Replace top slat panel and secure in place using the 4 off M8 cap screws provided.

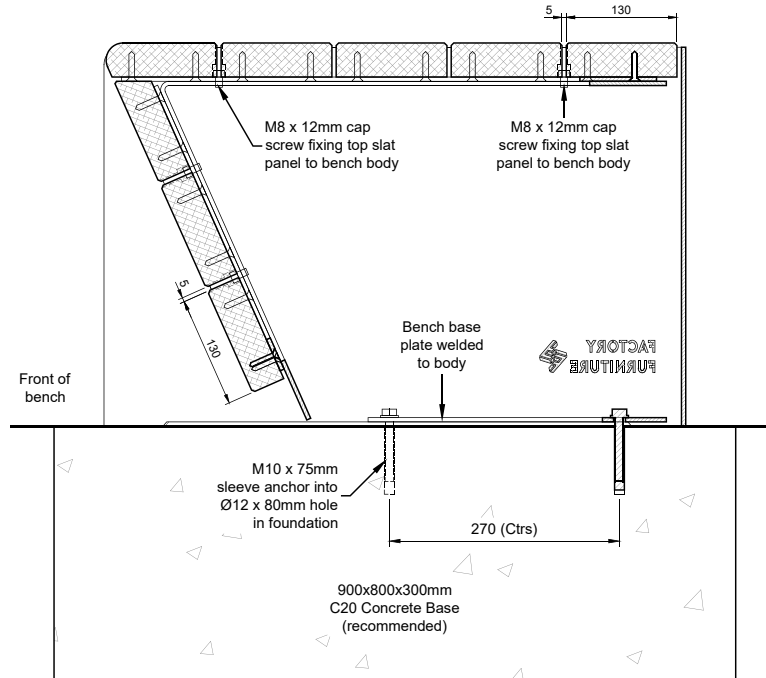

X-Section Thro' Bench

5 Pioneer Road, Faringdon,
Oxfordshire SN7 7BU
+44 (0)1367 242731
hello@factoryfurniture.co.uk

factoryfurniture.co.uk

