

FACTORY FURNITURE



TORD Table

Introduction

Design

Design, shop drawings and development by Factory Furniture Ltd

Manufacture

Factory Furniture manufactured components. Products are assembled in Factory workshops, checked and dispatched ready for installation. Replacement products or components should be ordered direct from Factory Furniture Ltd.

Copyright

The design copyright for the product and drawing copyright remains the sole property of Factory Furniture Ltd.

Timber

All timber used in Factory Furniture products is FSC® certified



Contents

Spec Sheet

TORD Table	... 3
TORD Picnic Set	... 4

Detailed Materials & Maintenance	... 5
----------------------------------	-------

Installation Instructions

TORD Table	... 6
TORD Picnic Set	... 7

NBS Specification	... 8
-------------------	-------

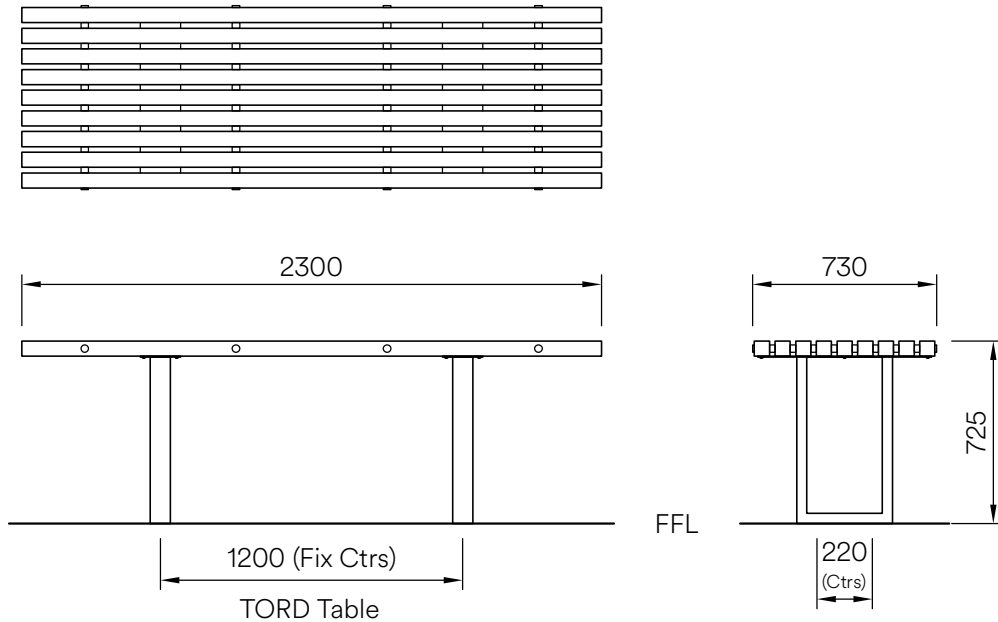

Composition

Slats - FSC® certified hardwood and aluminium spacers

Bases - Mild steel

Finishes

Timber - Untreated sanded finish as standard

Mild steel - Hot-dip galvanised (polyester powder-coated finish available (colour as per client's specification))

Dimensions

Metric length 2300mm | width 730mm | height 725mm

Imperial length 7' 6½" | width 2' 4½" | height 2' 4½"

Approx weight

109kg

Fixing centres & method

1200mm (3' 11") x 220mm (8½") - 4 off M10 resin stud anchors

Foundation

2 no. pads 400 x 800 x 300 mm in C20 concrete (recommendation only)

Handling

Please observe health & safety lifting guidelines. A forklift or crane will be required for off-loading and positioning of this product.

Maintenance

Depends on usage and position. All elements will require cleaning annually. Galvanised and powder coated mild steel only require maintenance if damaged.

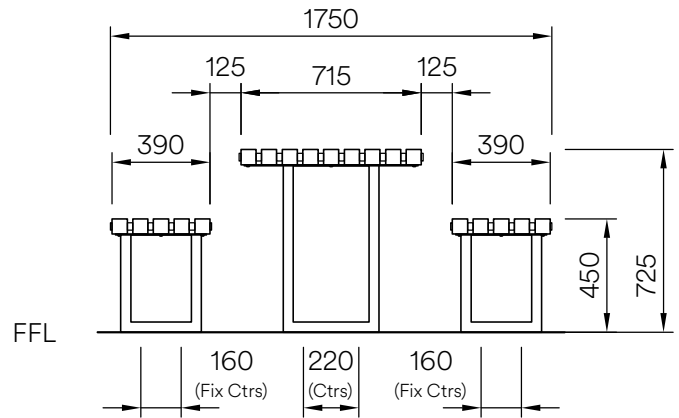
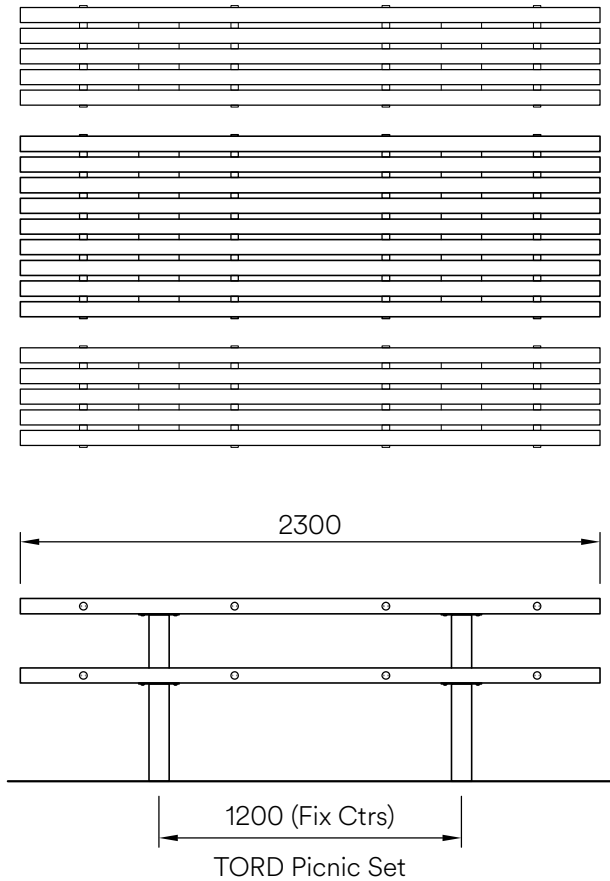

Composition

Slats - FSC® certified hardwood and aluminium spacers

Bases - Mild steel

Finishes

Timber - Untreated sanded finish as standard

Mild steel - Hot-dip galvanised (polyester powder-coated finish available (colour as per client's specification))

Dimensions

Metric length 2300mm | width 1750mm | height 725mm

Imperial length 7' 6½" | width 5' 9" | height 2' 4½"

Approx weight

233kg total (Table - 109kg Bench - 62kg each)

Fixing centres & method

(T) 1200mm (3' 11") x 220mm (8½"). (B) 1200mm (3' 11") x 160mm (6½") - 12 off M10 resin stud anchors

Foundation

2 no. pads 400 x 1750 x 300 mm in C20 concrete (recommendation only)

Handling

Please observe health & safety lifting guidelines. A forklift or crane will be required for off-loading and positioning of this product.

Maintenance

Depends on usage and position. All elements will require cleaning annually. Galvanised and powder coated mild steel only require maintenance if damaged.

Detailed Material & Finish Specifications

Slats

- Manufactured from FSC® certified hardwood. Slats are profiled, sanded and left untreated as standard
- Slats assembled using aluminium endcaps, spacers and concealed stainless steel tie rods.
- Bolted onto 2 no. bases

Bases

- Manufactured from mild steel as standard (all welded fabrication) with a hot-dip galvanised finish (polyester powder coat available (colour as per customer specification))
- Anchored using 4 no. M10 x 160mm resin stud anchors per table. (12 no. M10 x 160mm anchors for picnic set)

General Maintenance (Recommended Schedule & Guidelines)

Daily/Weekly/Monthly (or as adopted)

Visual checks of slats and bases - check all items for superficial or physical damage.

Three Monthly

Clean all items as detailed below check all fixings are seated correctly; inspect timber for serious damage and splinters.

Six Monthly

Secure all fixings; full clean as detailed below; check that table is firmly secured to the ground

Specific Maintenance Details

FSC Timber

Clean with a stiff brush once per year, especially in more exposed locations, in order to prevent a verdigris type build up on the timber surface. Ideally this should be completed in early spring. During the cleaning stage, all exposed timber surfaces should be inspected for splits and splinters. Any splinters and graffiti should be removed and the surface sanded with 100 grit sandpaper in order to remove any uneven / sharp edges or surfaces.

During the first few months after installation the tannin naturally occurring in the timber may leach out and cause a brown staining on the bases. This may be removed with a light solution of household bleach and water.

Galvanised & Polyester Powder Coated

For general cleaning using a damp cloth and warm soapy water only. Scourers and abrasive cleaners are NOT suitable for this type of finish and may damage it. Before using any cleaning agents to remove graffiti etc. try on a small, inconspicuous area first to avoid causing more unsightly damage.

Repairs

FSC Timber

For light damage, please see section on specific maintenance details above. For instances of heavy damage, the timber item should be replaced. Please order against the part number reference in the reordering section towards the end of this manual.

Galvanised & Polyester Powder Coated Surfaces

For light damage (scratches, chips etc.) repair using touch-up paint to match original colour (available from Factory Furniture Ltd). Paint application should be carried out in accordance with approved methods detailed by the paint manufacturer. Please note that it is advisable to use professional painters to achieve best results when touching up larger areas. Products for respraying larger areas are available from Factory Furniture Ltd.

Heavy Damage

In the event of serious damage to any component, replacements should be ordered from Factory Furniture Ltd. Should further assistance be required (or if the product needs to be disassembled for any reason), please contact Factory Furniture for detailed technical advice.

Installation Instructions

ALL INSTALLATION WORKS TO BE CARRIED OUT BY COMPETENT PERSONNEL - INSTALL AS COMPLETE UNIT

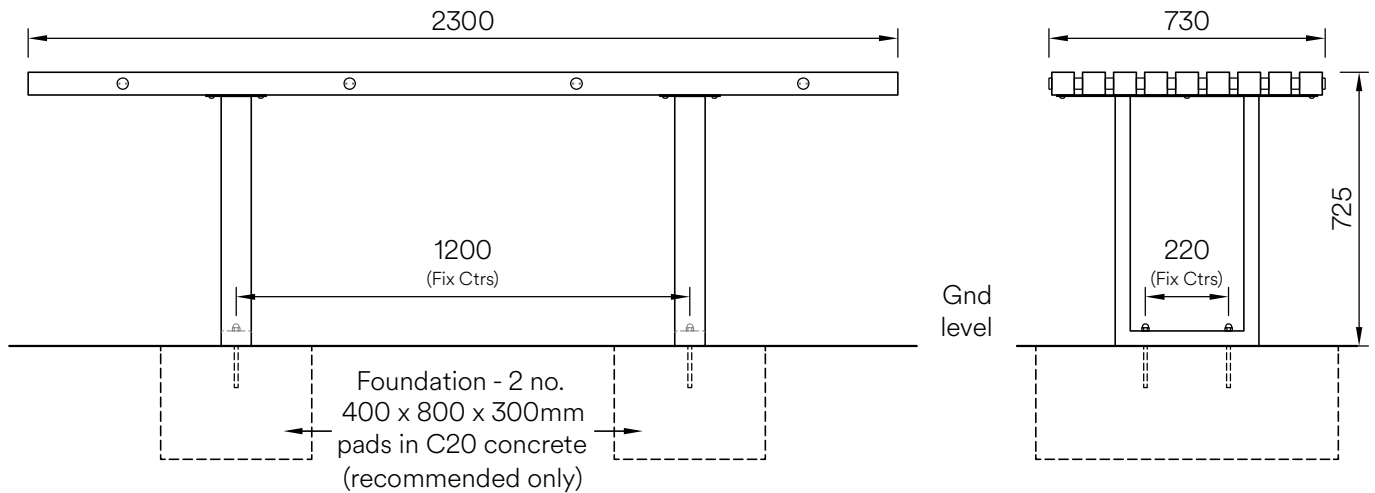

Tord Table

1. Install suitable foundation pads (see illustration) with top faces at ground level
2. Position table in desired location with bases centred on foundation pads then mark hole positions onto pads
3. Remove the table; drill holes $\text{\O}12\text{mm}$ x 125mm deep (or as per manufacturer's recommendations)
4. Clear debris from holes
5. Fill the holes to within approximately 35mm from the top with Hilti HY150 resin (or similar)
6. Screw capnuts onto resin anchor studs (leaving room for final tightening)
7. Move table back into position (if necessary use shims to get table level) and drop resin anchor studs with capnuts into the holes in bases - leave for two hours before proceeding.
8. Using a torque wrench, tighten capnuts onto base to 20Nm to fasten down the table.
9. Check levels.

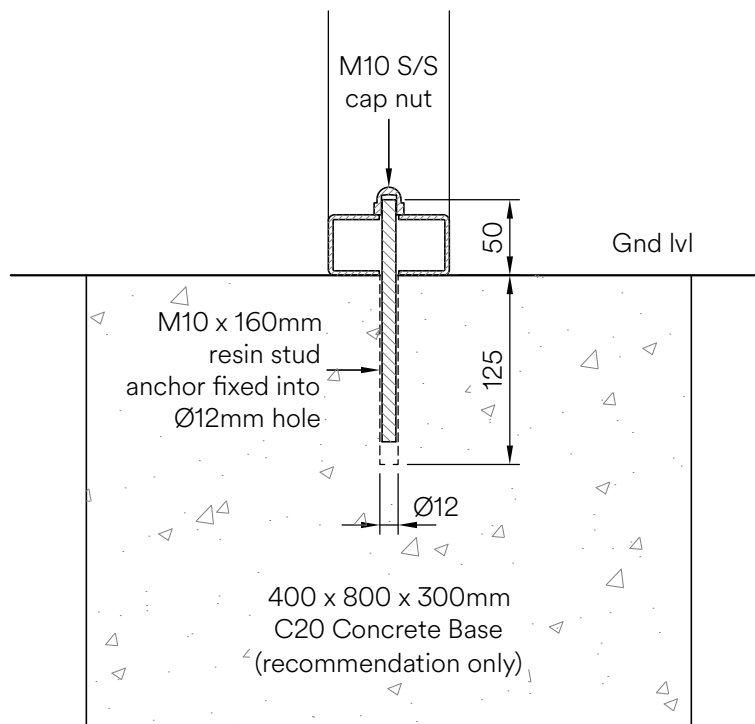

Installation Instructions

ALL INSTALLATION WORKS TO BE CARRIED OUT BY COMPETENT PERSONNEL - INSTALL AS COMPLETE UNIT

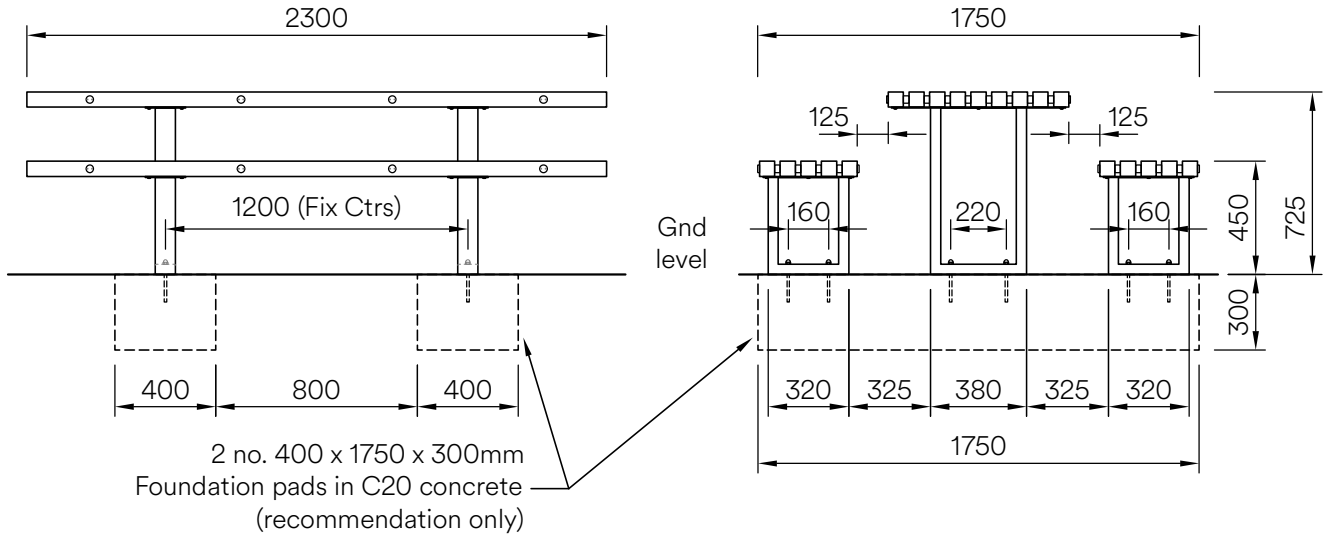

Tord Picnic Set

1. Install suitable foundation pads (see illustration) with top faces at ground level
2. Position table and benches in desired location with bases centred on foundation pads and mark hole positions on pads
3. Remove the table and benches; drill holes $\text{\O}12\text{mm}$ x 125mm deep (or as per manufacturer's recommendations)
4. Clear debris from holes
5. Fill the holes to within approximately 35mm from the top with Hilti HY150 resin (or similar)
6. Screw capnuts onto resin anchors (leaving room for final tightening)
7. Move table and benches back into position (if necessary use shims to get table level) and drop resin anchor studs with capnuts into the holes in bases - leave for two hours before proceeding.
8. Using a torque wrench, tighten capnuts onto bases to 20Nm to fasten down the table and benches.
9. Check levels.

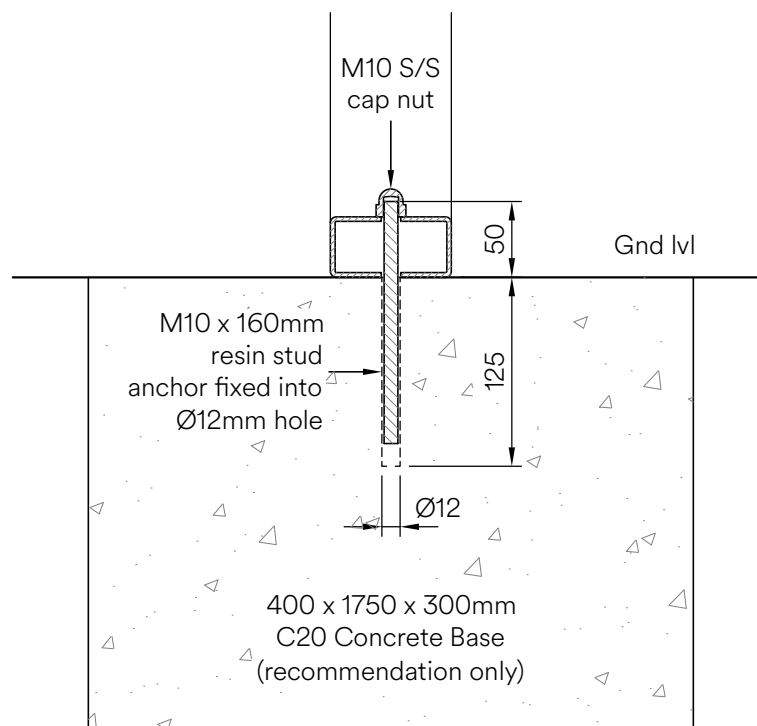

NBS Specification Data

PRODUCT REFERENCE – FF2007 – TORD TABLE

Description Table with galvanised mild steel frame and timber slats
Uniclass 2015 Category Pr_40_30_30_86 Street and site tables
Design as per drawing: FF2007

MANUFACTURER

Name Factory Furniture Ltd
Address Unit 5 Pioneer Road, Faringdon, Oxfordshire, SN7 7BU
Website www.factoryfurniture.co.uk
Telephone +44 (0)1367 242731

MATERIAL

Slats FSC® certified hardwood
Frame Mild steel

FINISH

Timber Untreated sanded finish as standard
Stainless steel Galvanised (polyester powder coat available (colour as per client specification))

SIZE

Table only (FF2007) 2300mm x 730mm x 725mm (LxWxH)
Picnic set (FF2007-P) 2300mm x 1750mm x 725mm (LxWxH)

FIXING

4 no. M10 x 160mm resin stud anchors (12 no. for picnic set)